

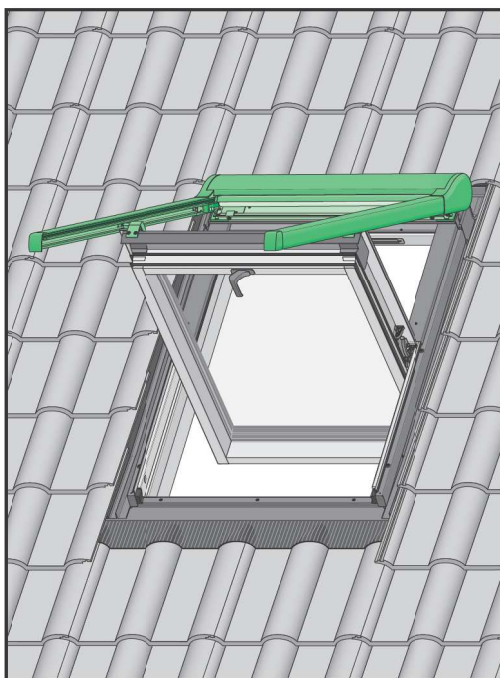

AMZ WiFi (2023)

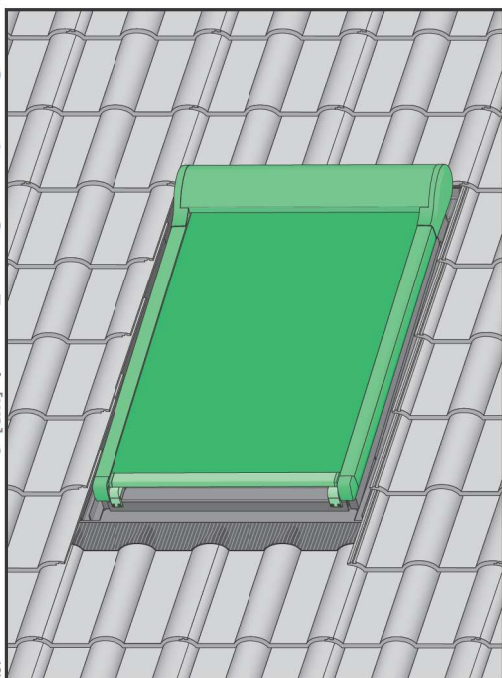

NC 955_AMZ WiFi (Tuya, F23)_24.01.04_FAKRO_KB3437

Smartphone icon with Tuya logo

Fakro Smart

ANDROID
iOS

Manual icon with page number 33

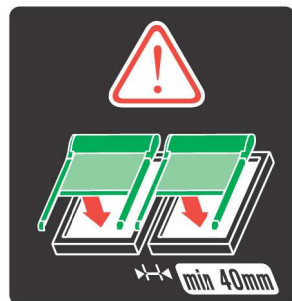

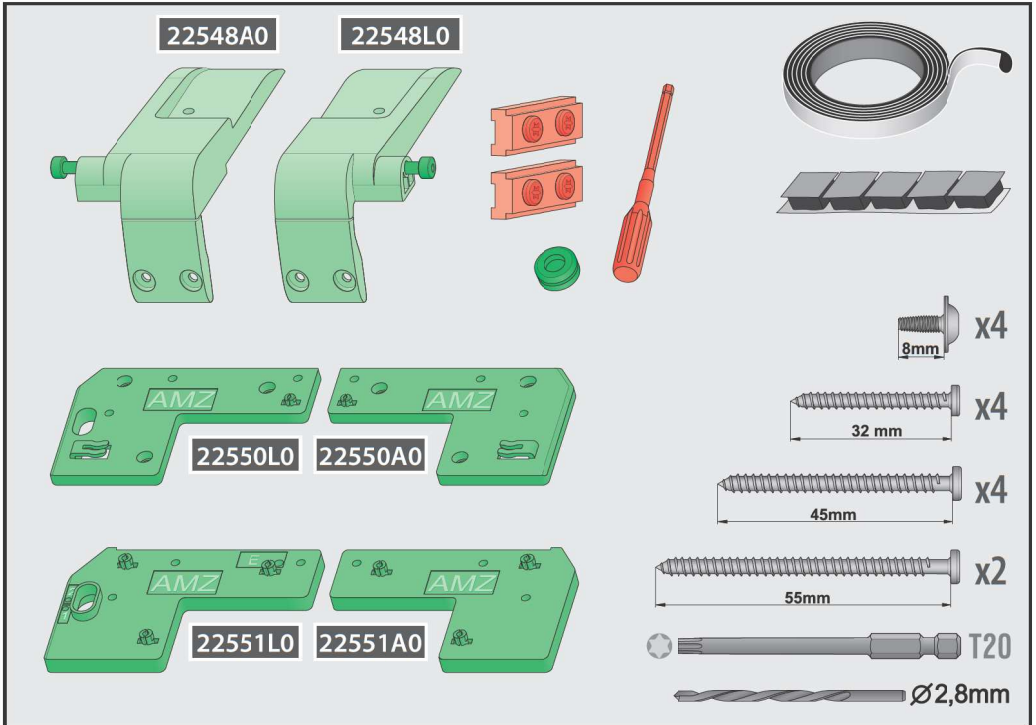
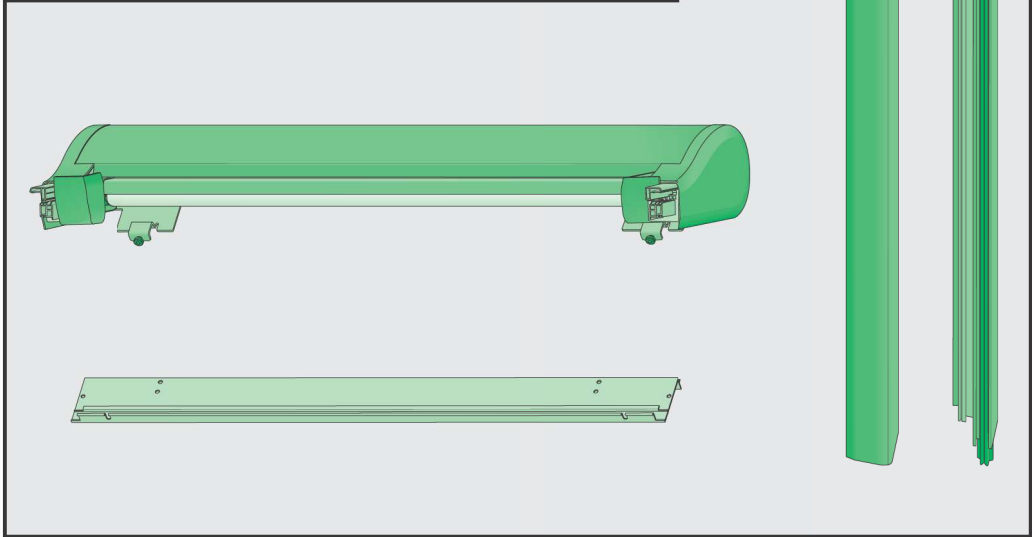
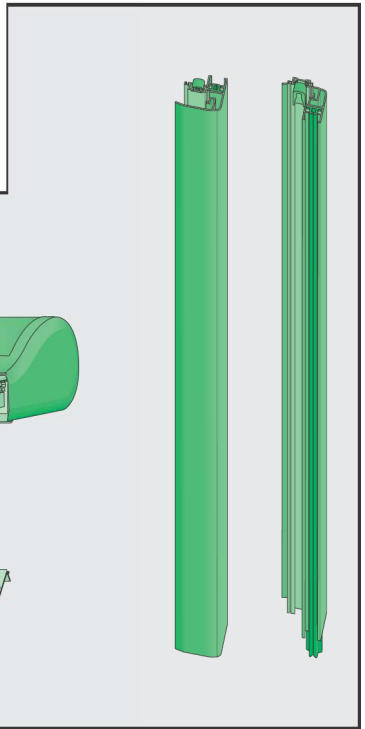

1 FTP-V, FTU-V, FTW-V, FPP-V, FTS, FTS-V, FTT, PTP-V, PPP-V, PTP

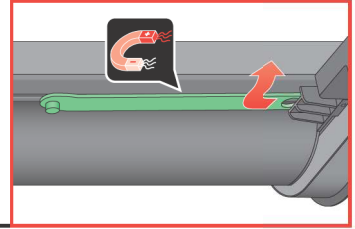

1* FYP-V, FDY-V, PYP-V

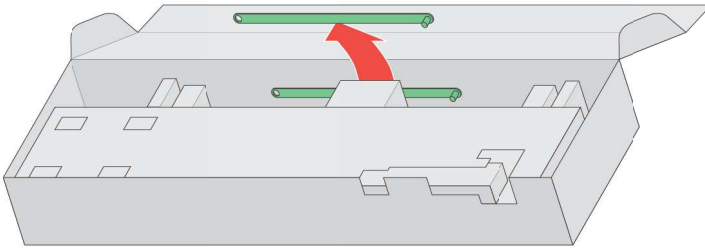

2

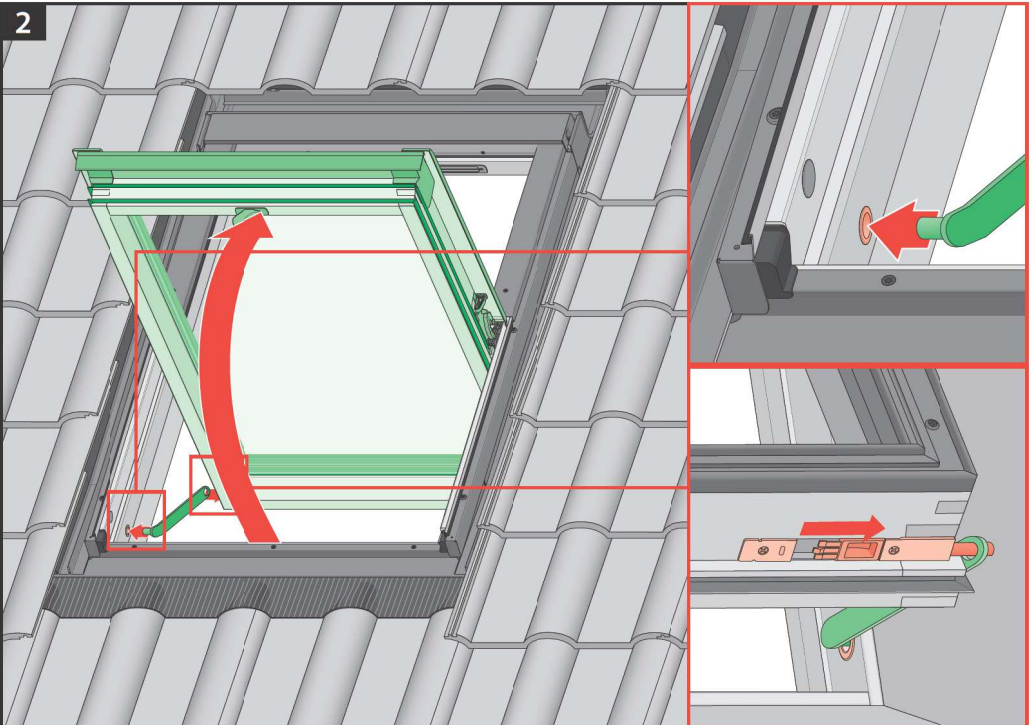

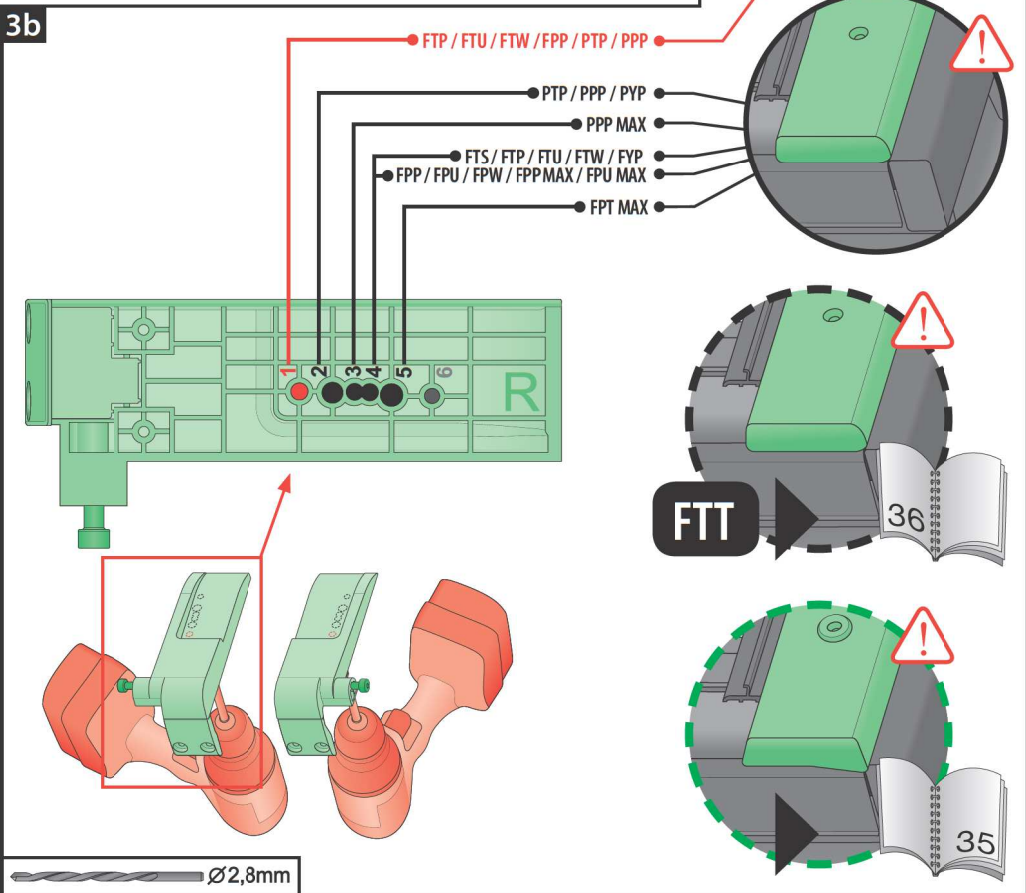
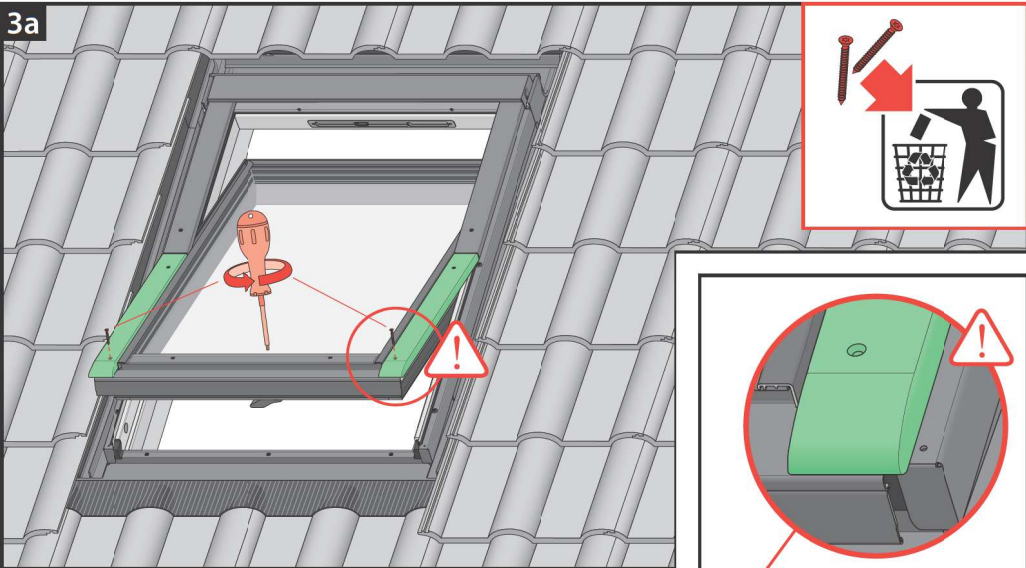

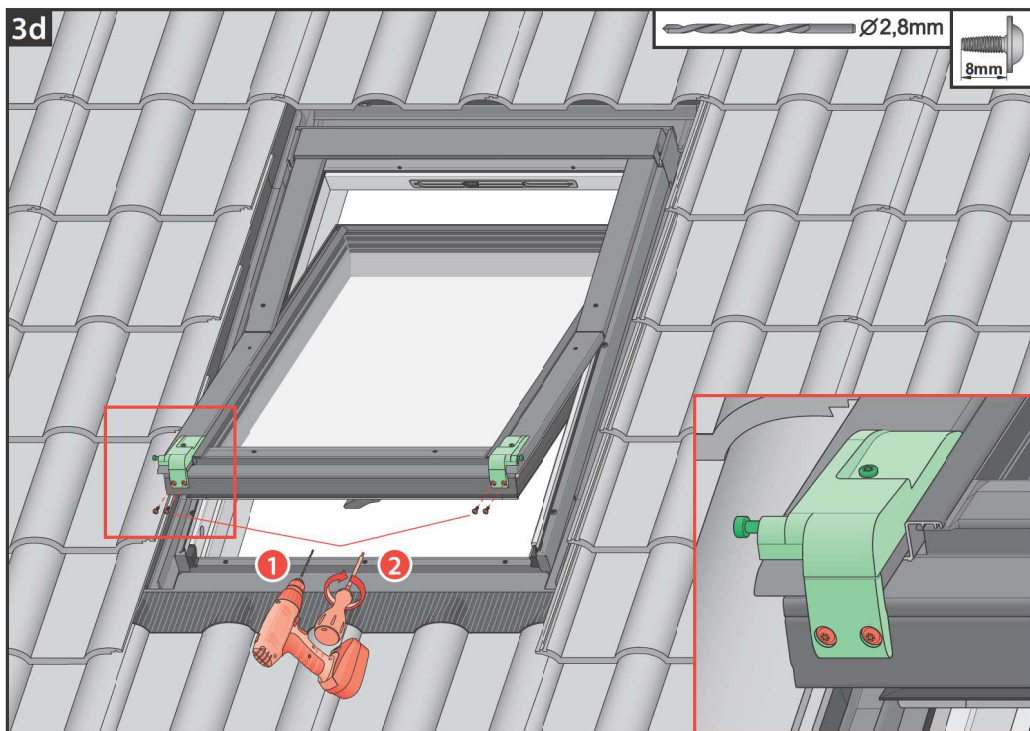
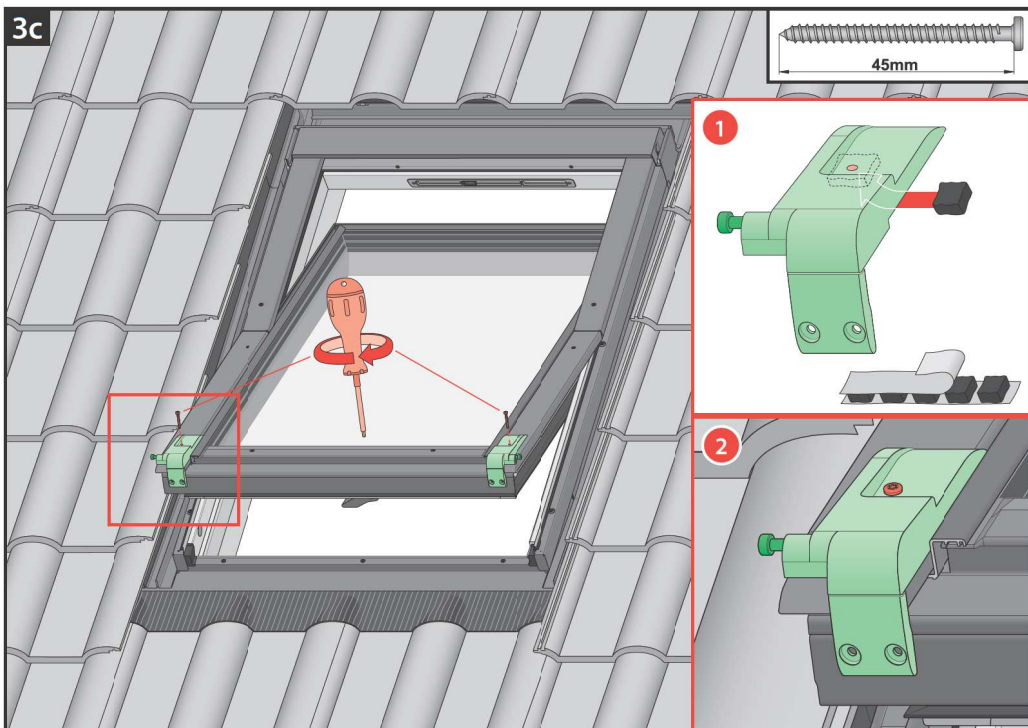

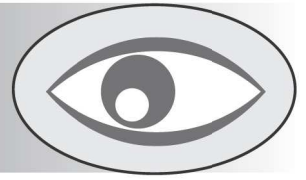

type WiFi

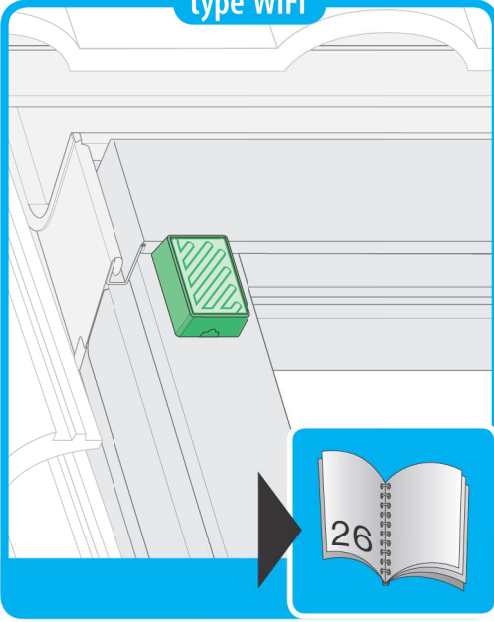

type A

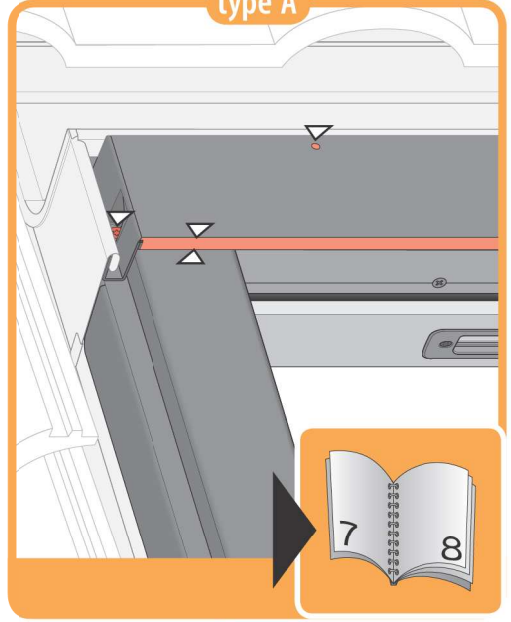

type B

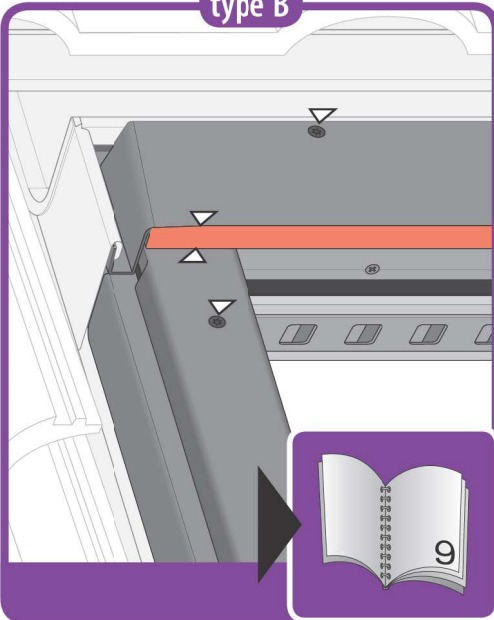

type C

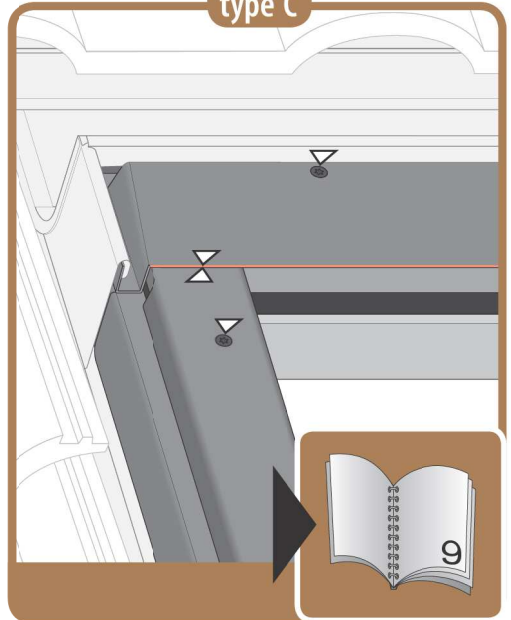

4a type A

Ø2,8mm MAX 5mm Ø10mm

22551L0

45mm

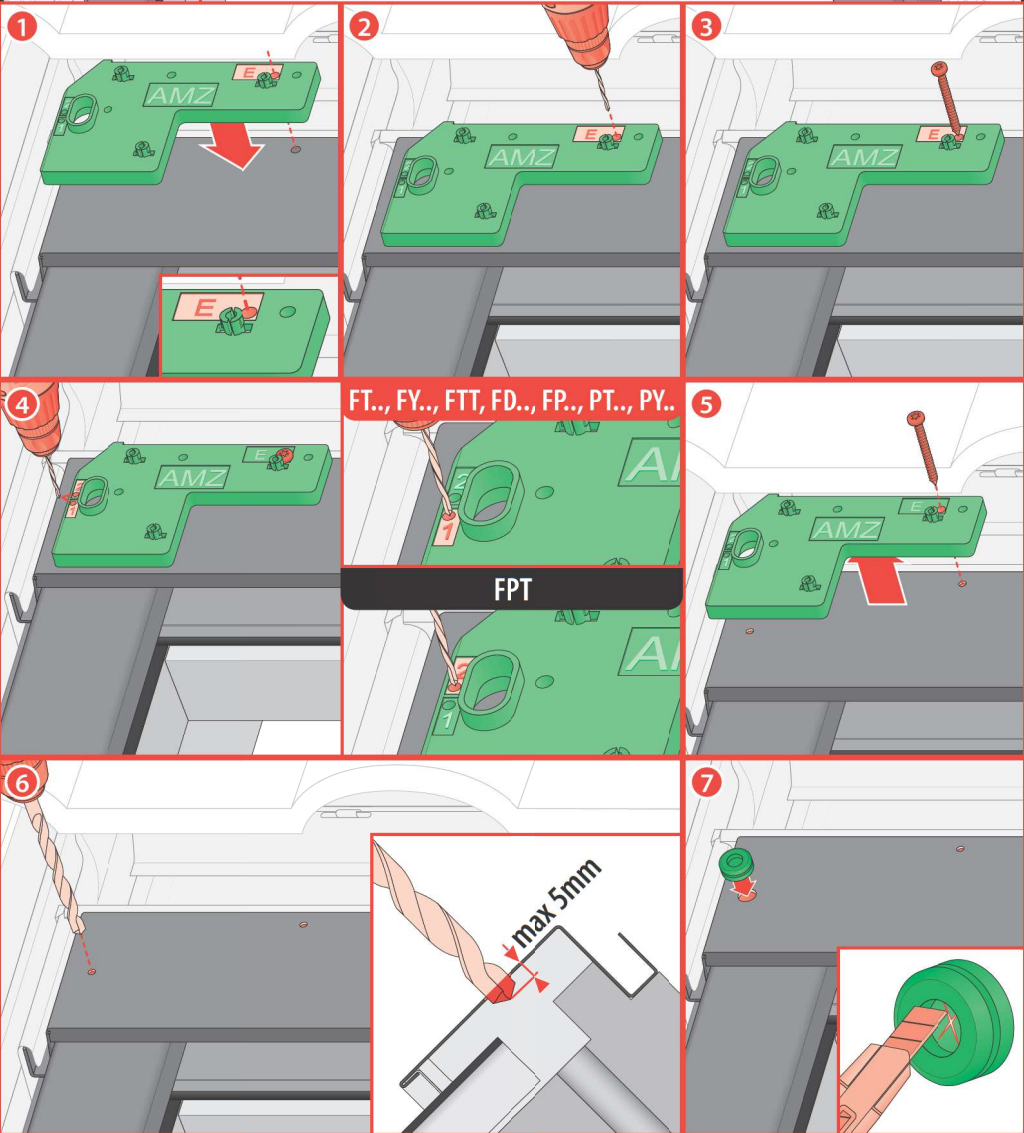

22551L0

22551A0

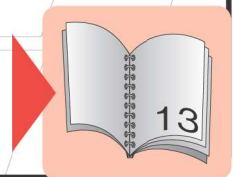
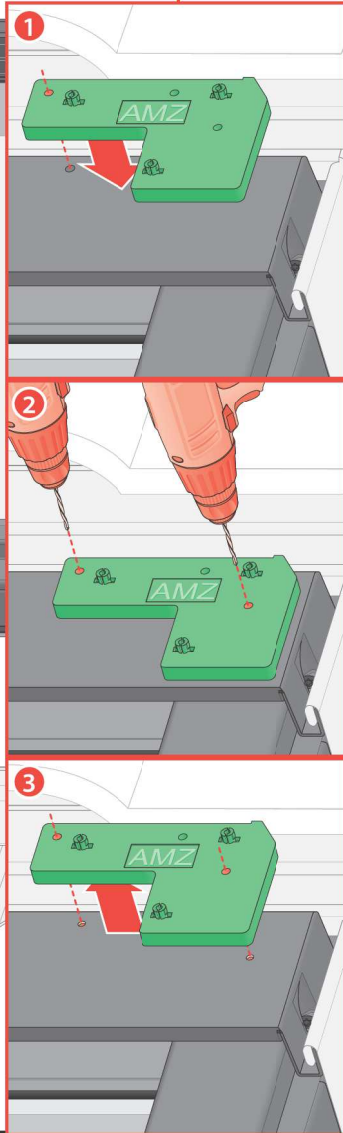
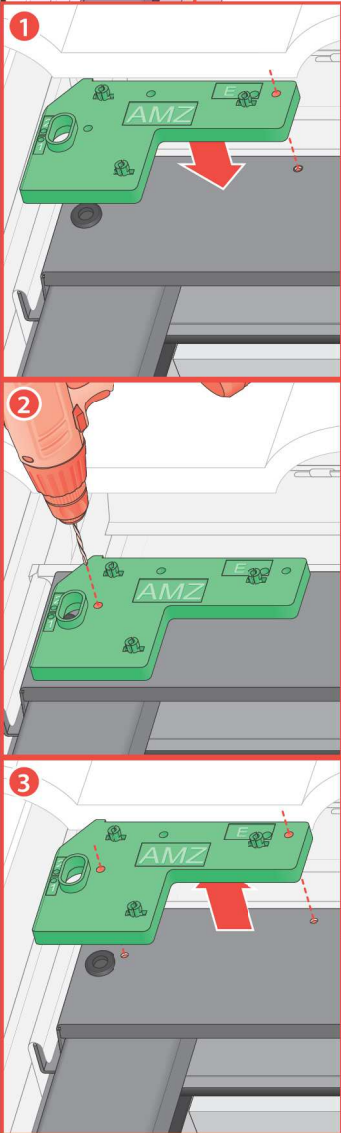

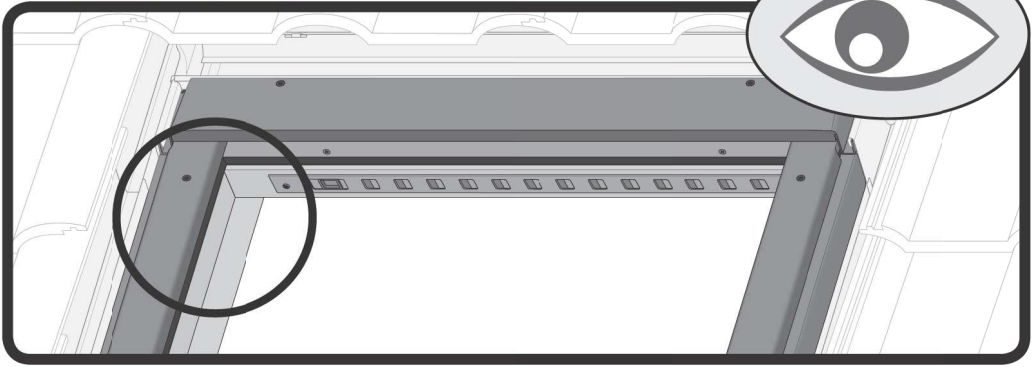
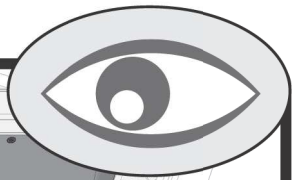

type X

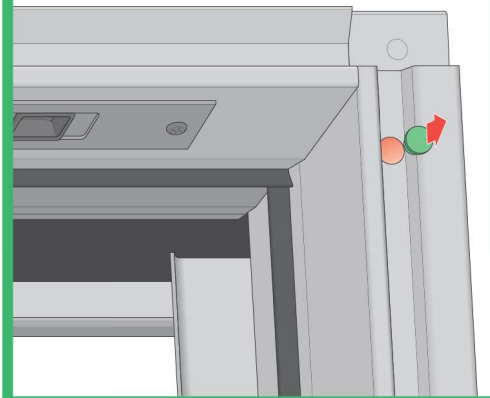

FTS, FTS-V, FTP, FTP-V, FYP, FYP-V
FTT, FDY-V, FPP preSelect 2
PTP, PTP-V, PYP, PYP-V

type Y

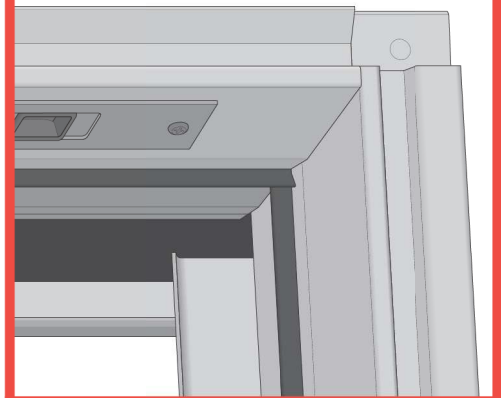

FTS, FTS-V, FTP, FTP-V, FYP, FYP-V
FTT, FDY-V, FPP preSelect
PTP, PTP-V, PYP, PYP-V

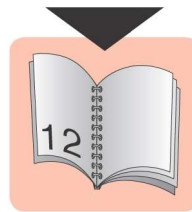
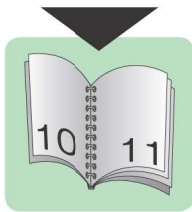

4b type X

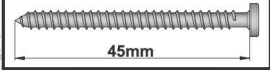

22551L0

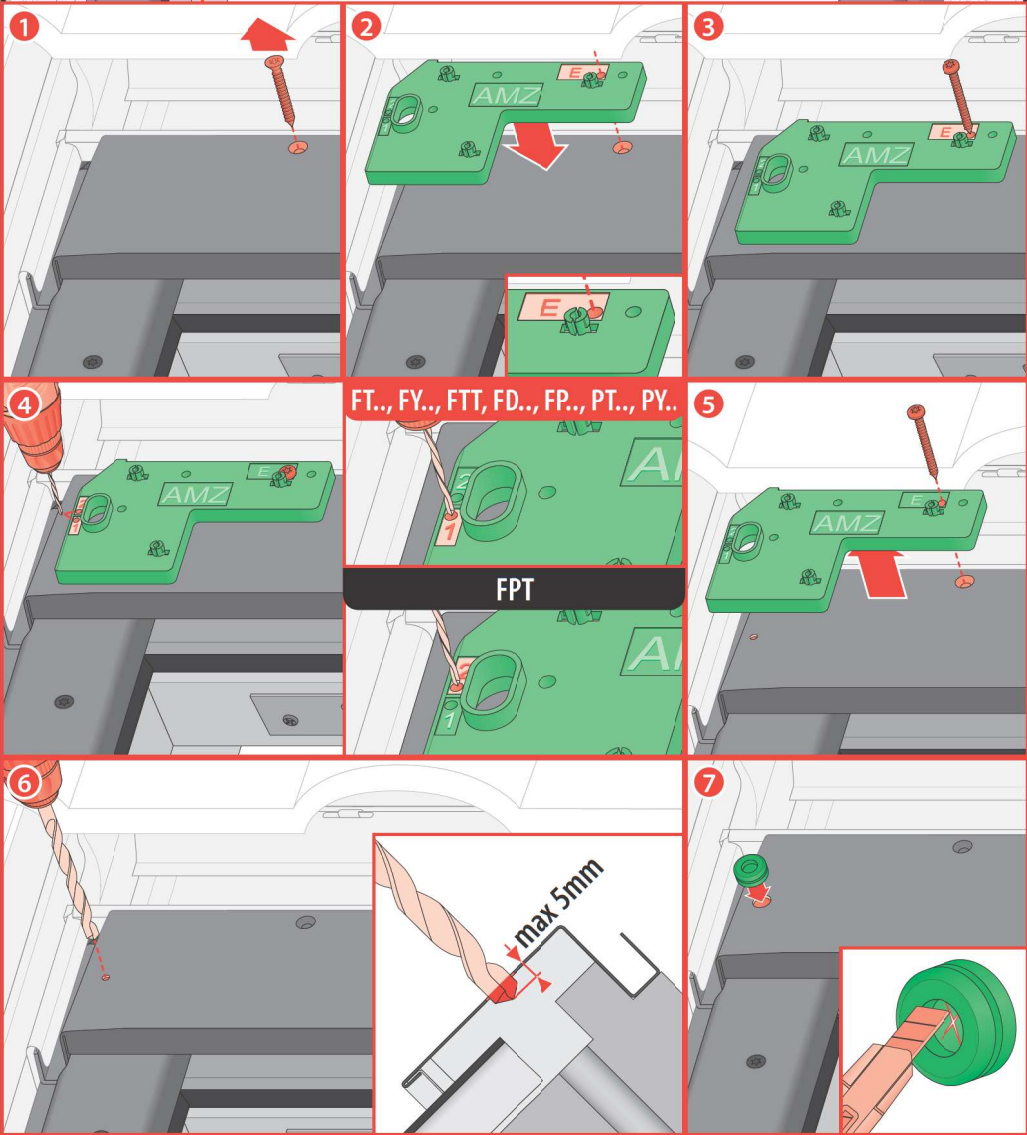
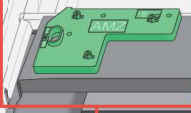

22551L0

22551A0

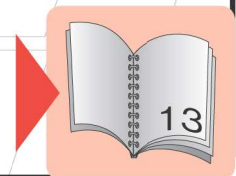
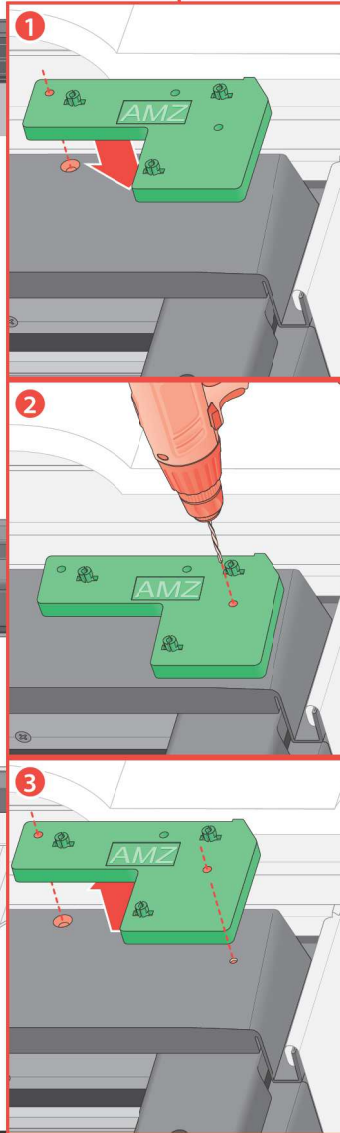
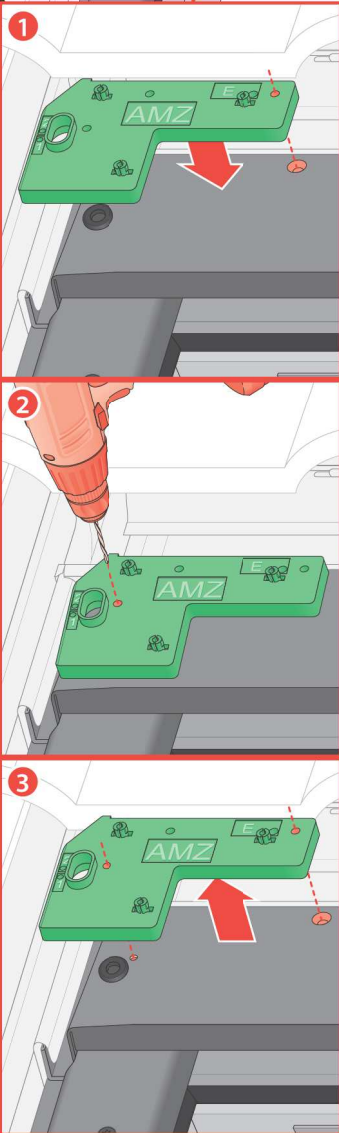

4a

type Y

Ø2,8mm

22551L0

22551A0

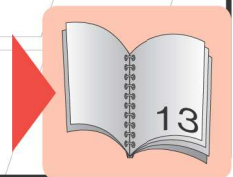
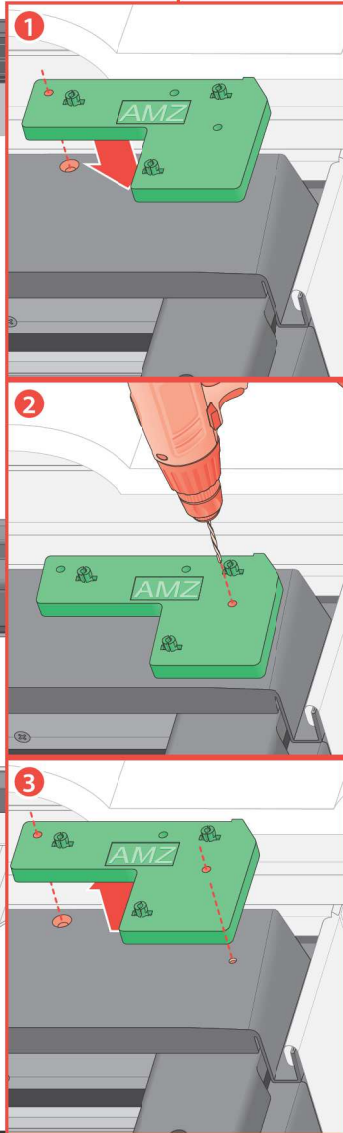
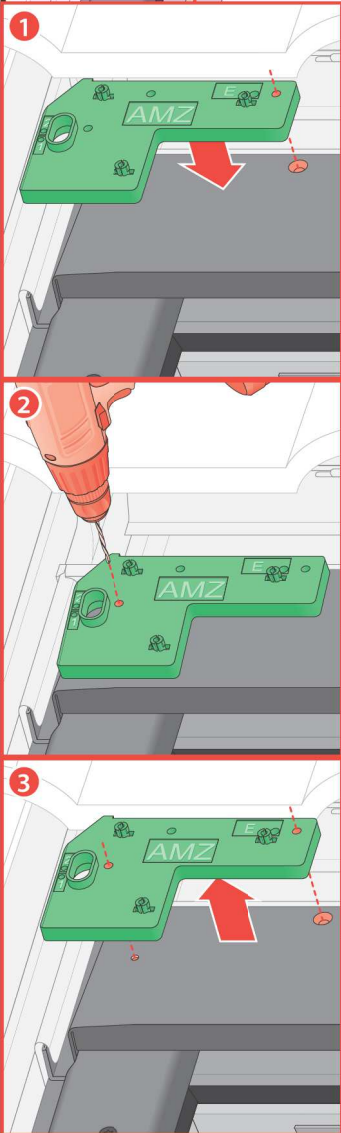

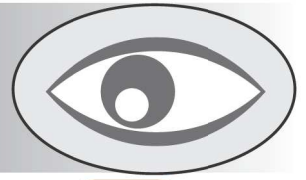

type A

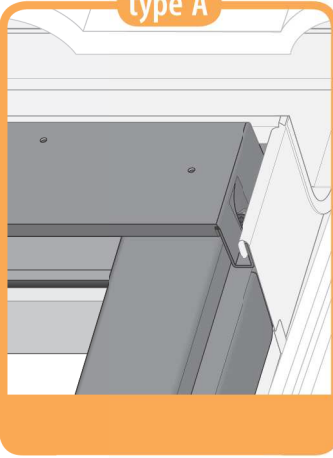

type B

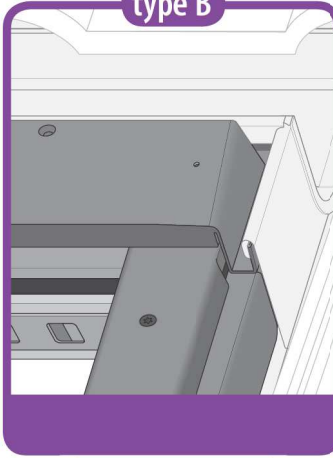

type C

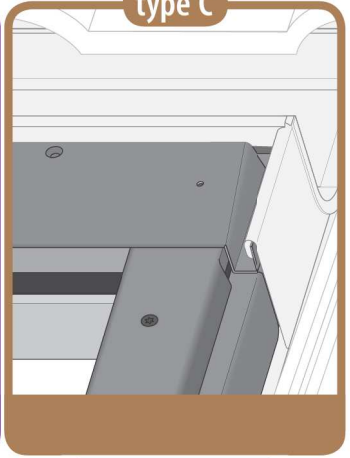

5a type A

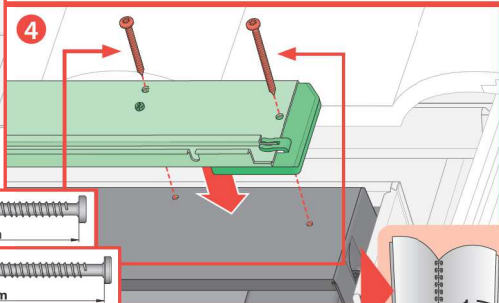
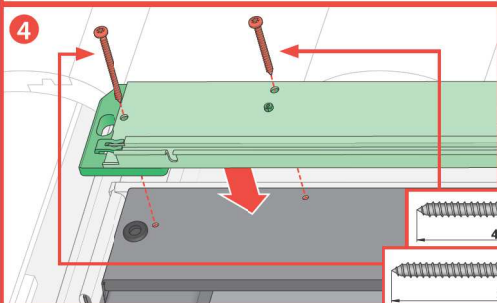
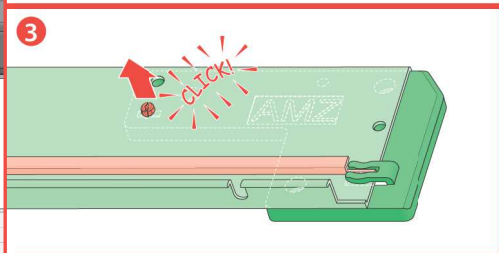
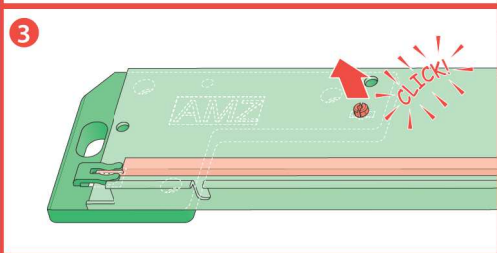
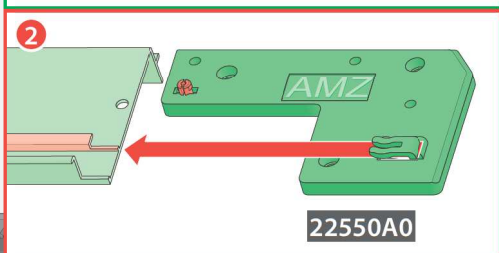
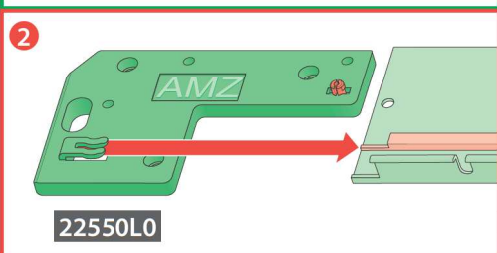
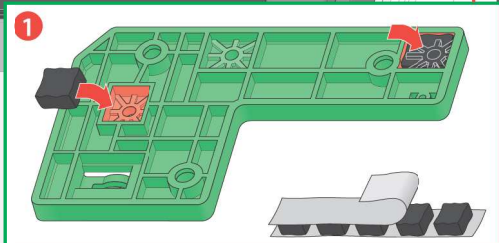
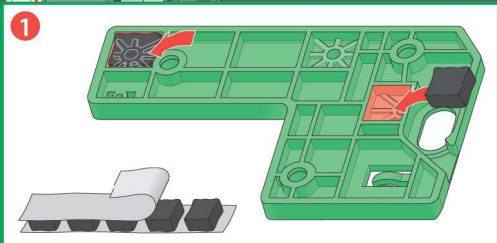
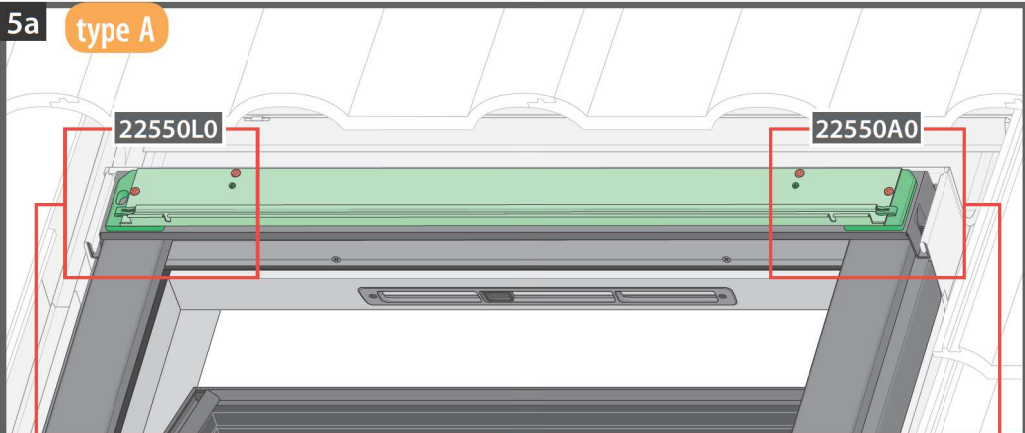

5b type B

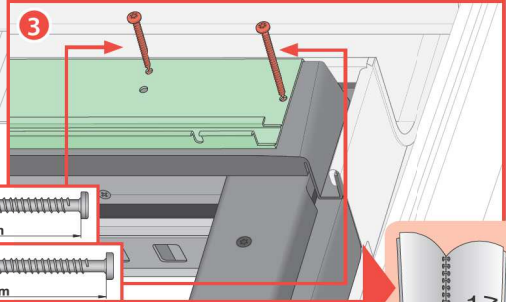
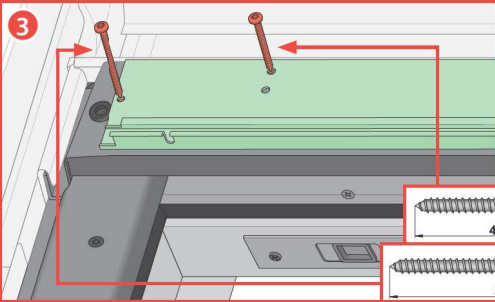
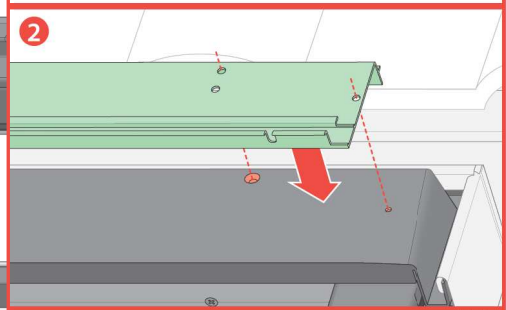
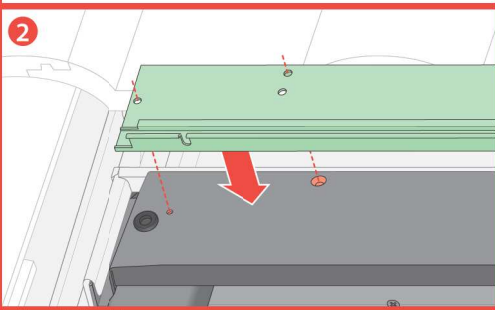
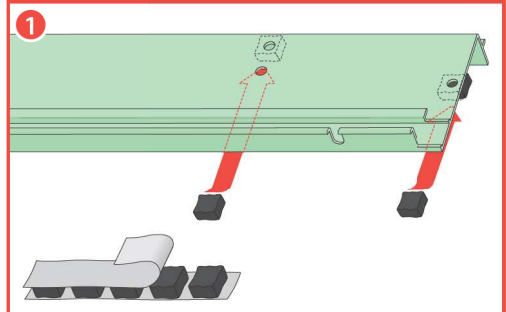
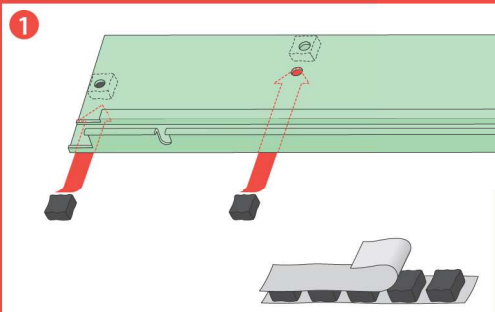

45mm



55mm



5c type C

22550L0

22551L0

22550A0

22551A0

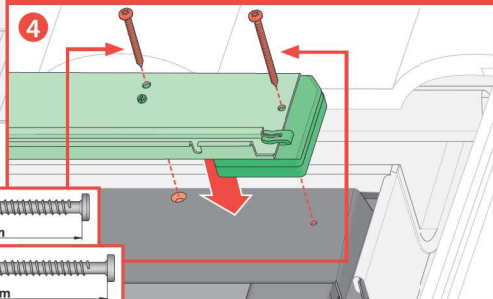
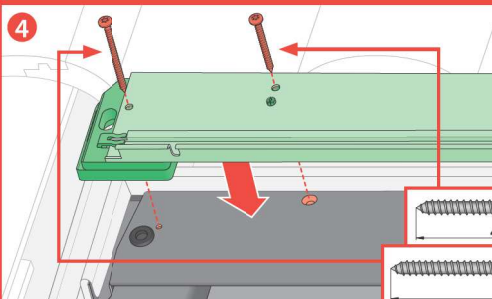
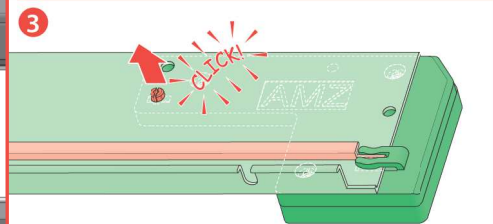
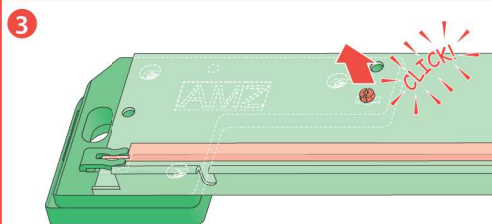
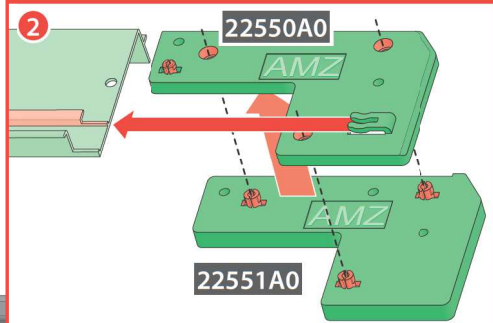
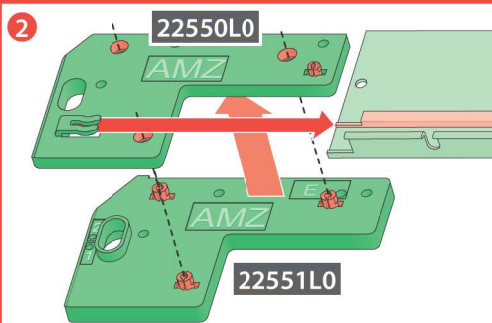
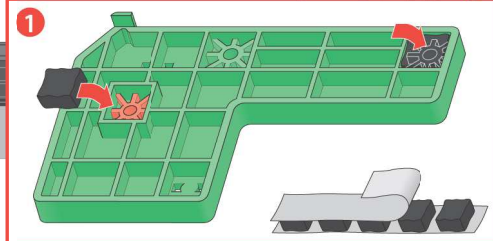
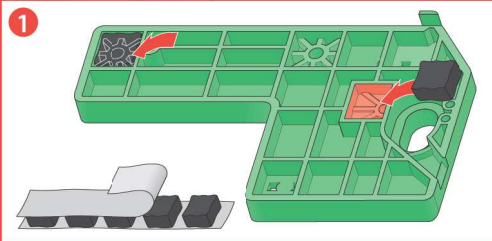

6

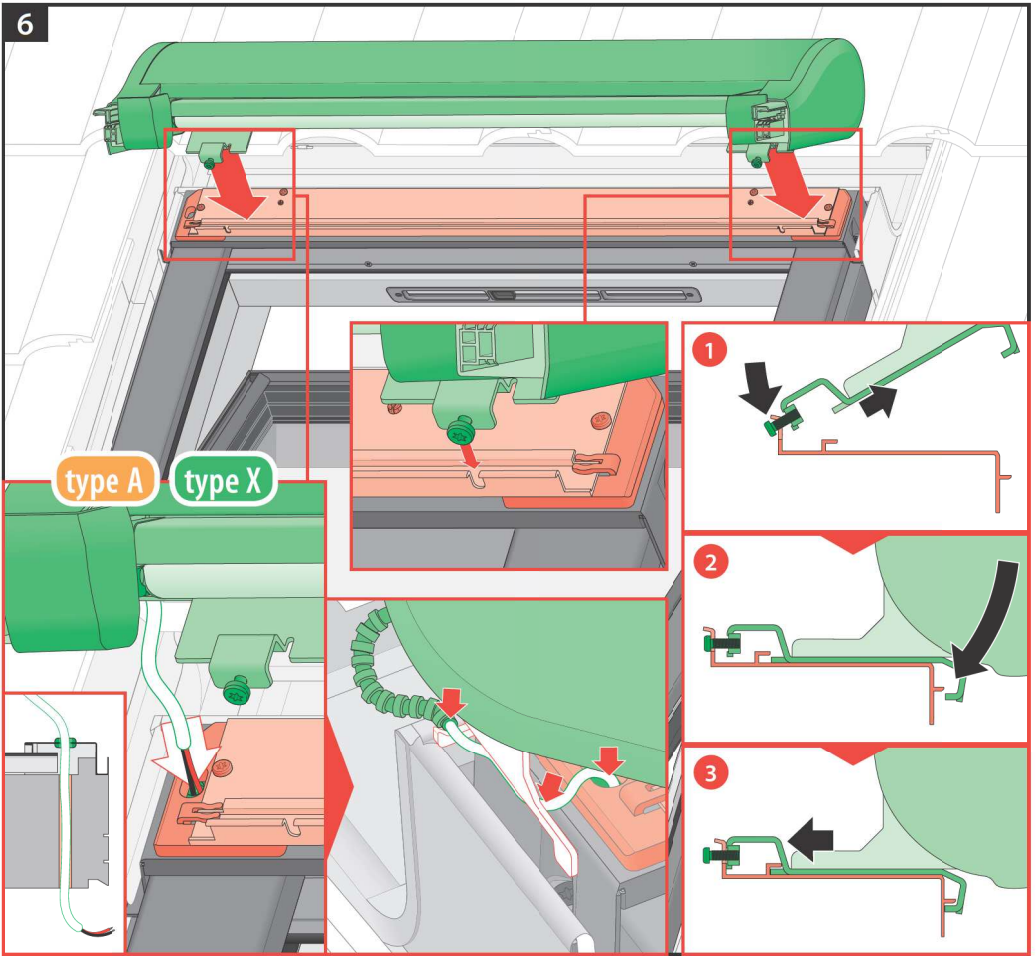

7

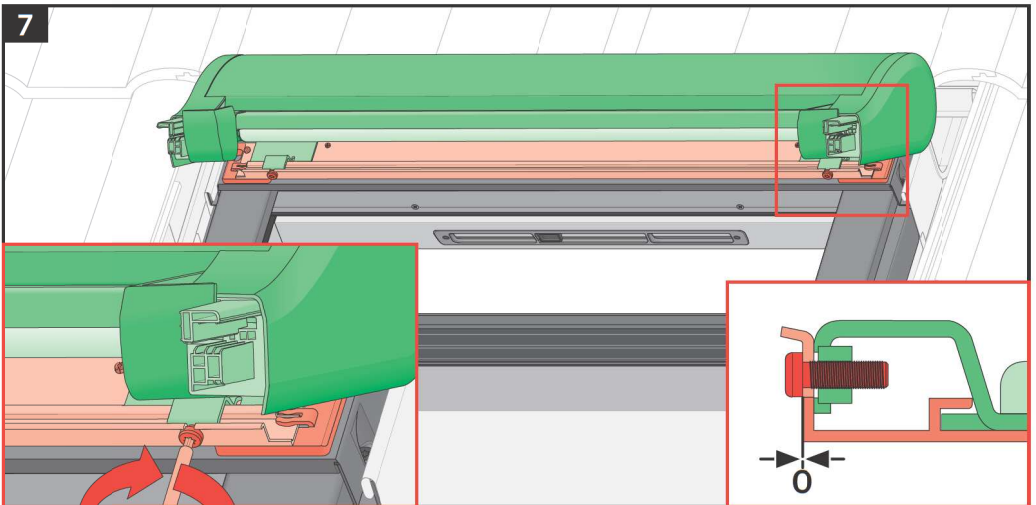

8*



FYP-V
FDY-V
PYP-V

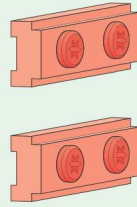

8a

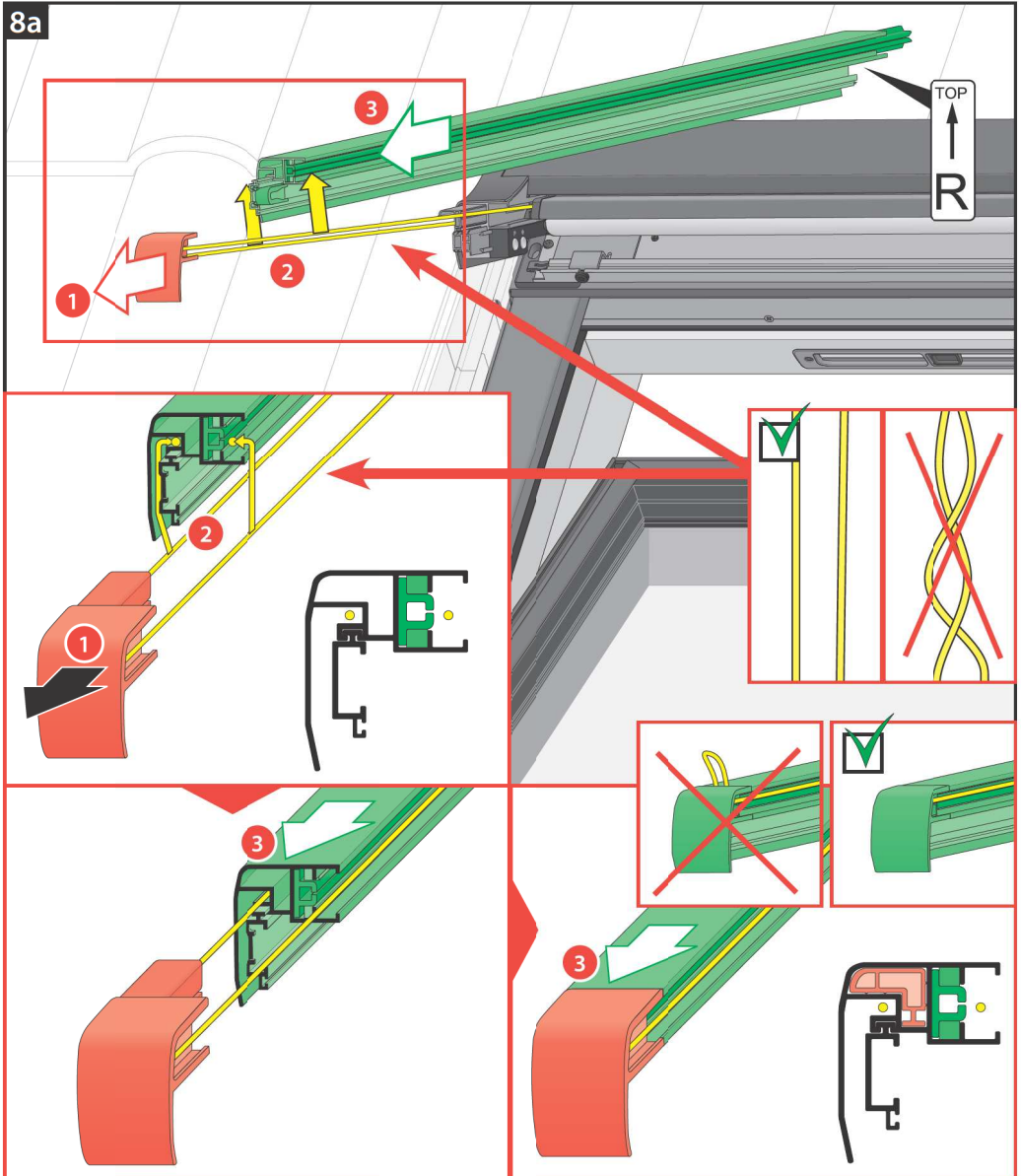

8b

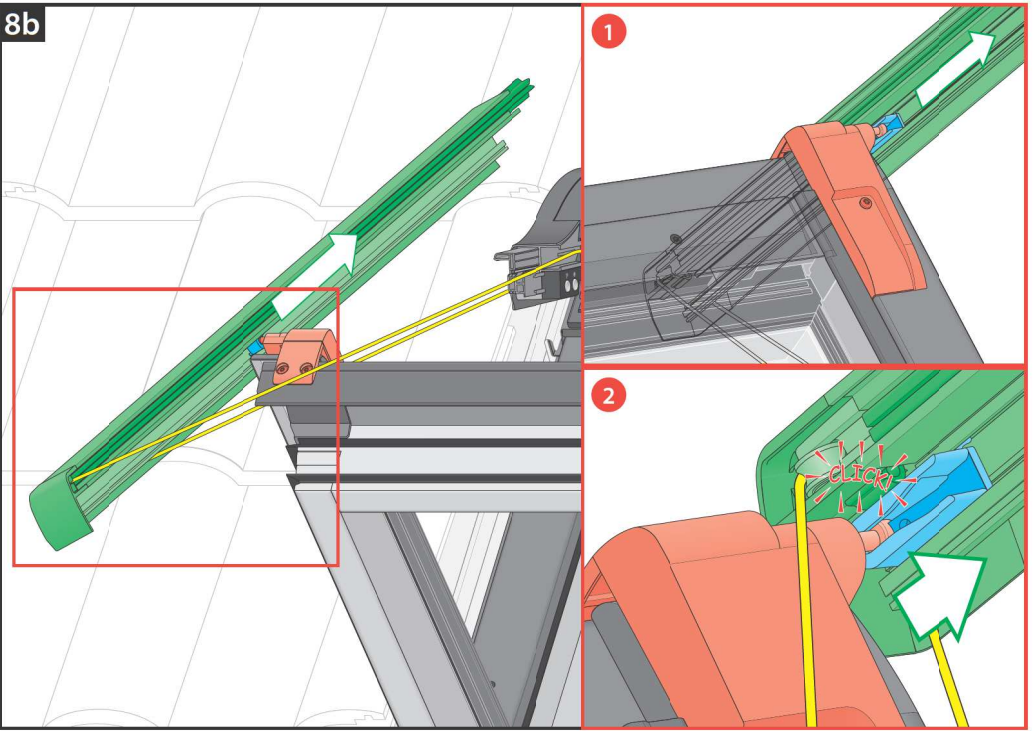

8c

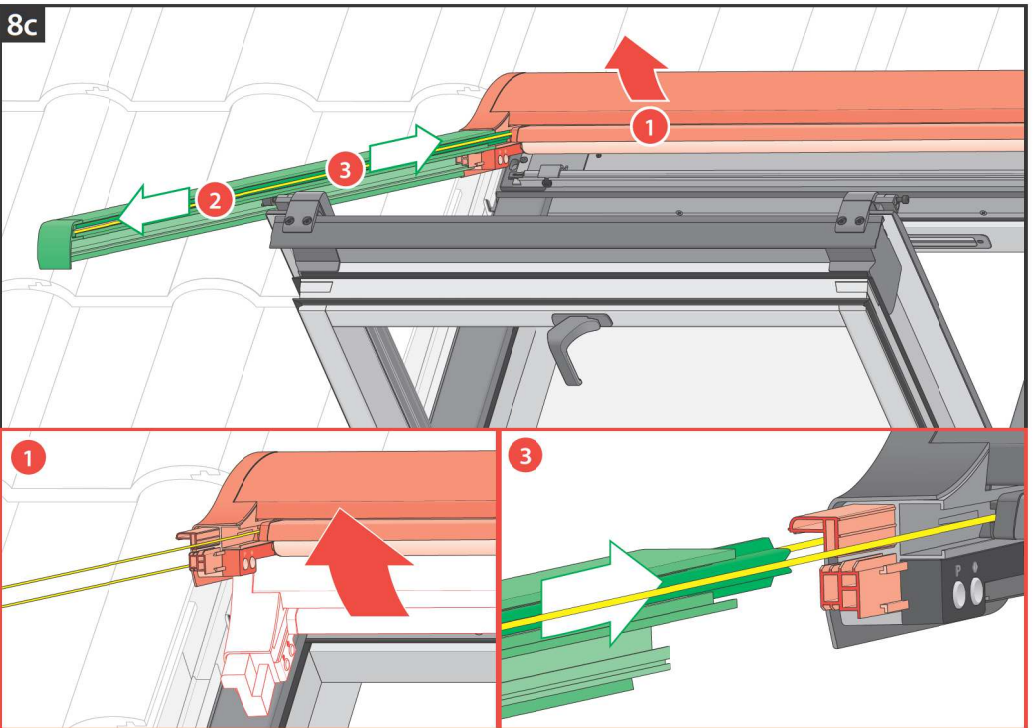

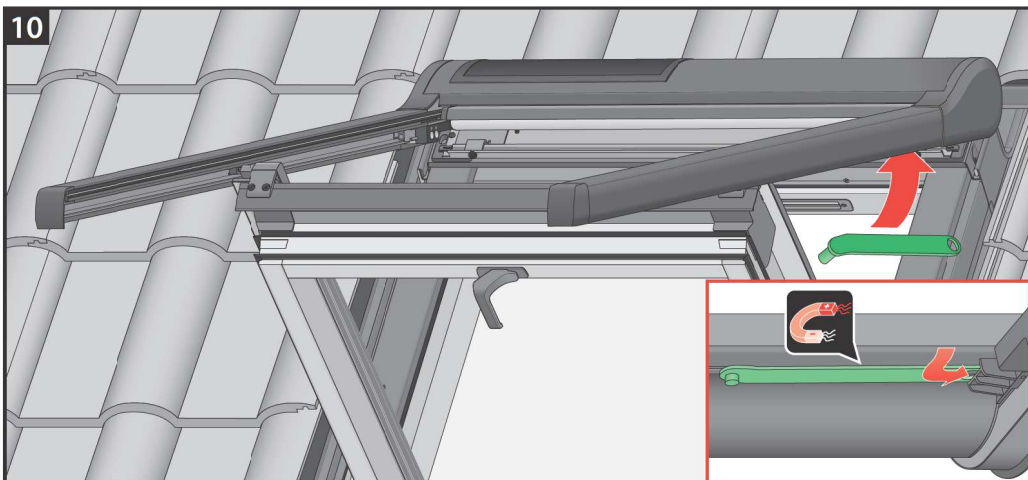
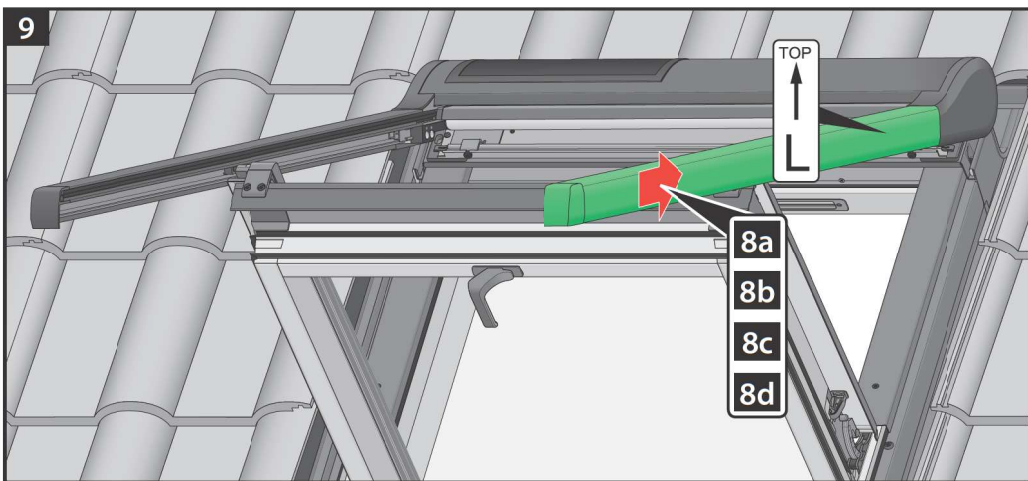
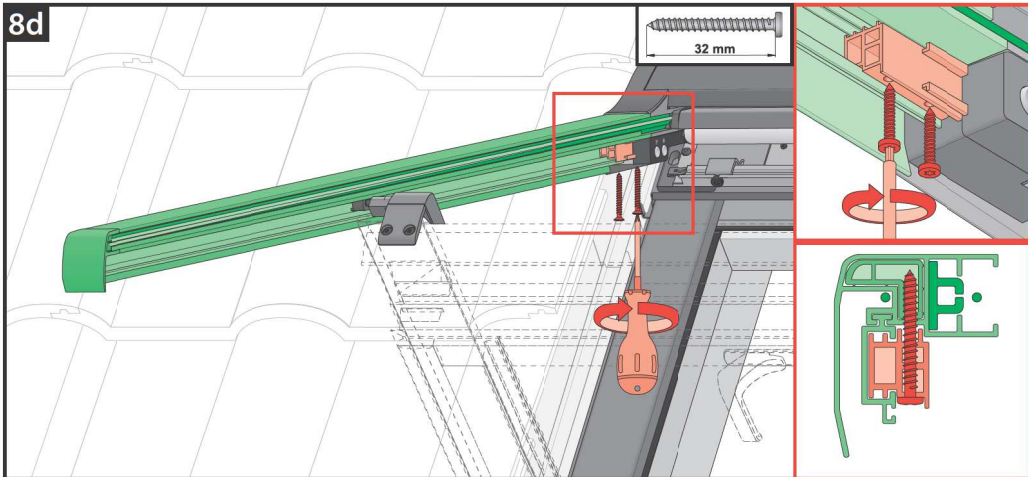

11

type WiFi

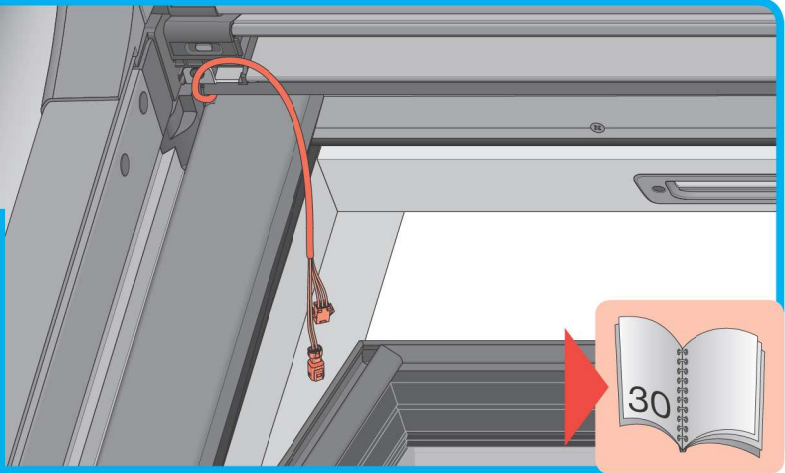

11

type A

type X

15V DC
1,2A
20W

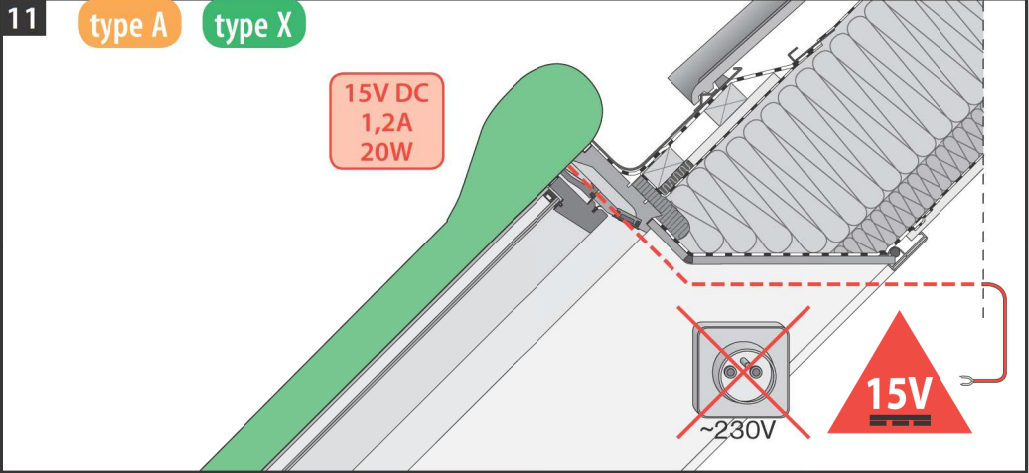

11

type Y

15V DC
1,2A
20W

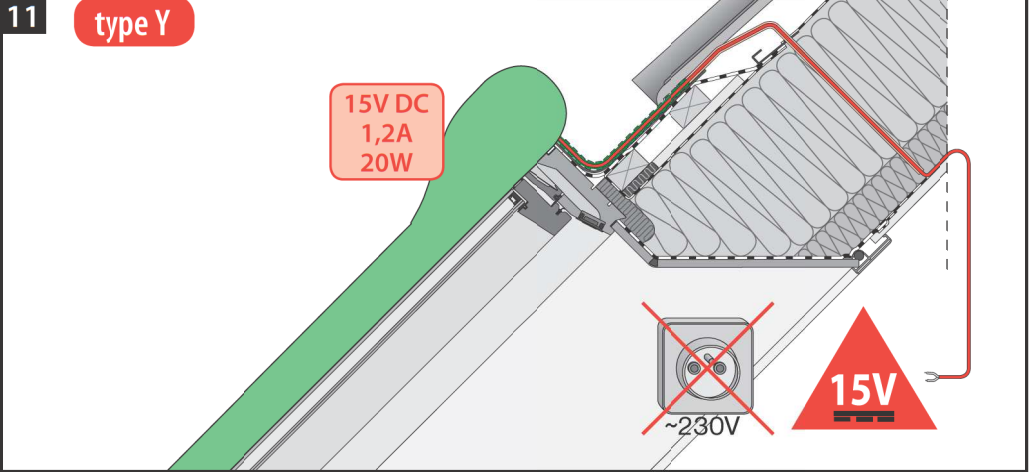

12

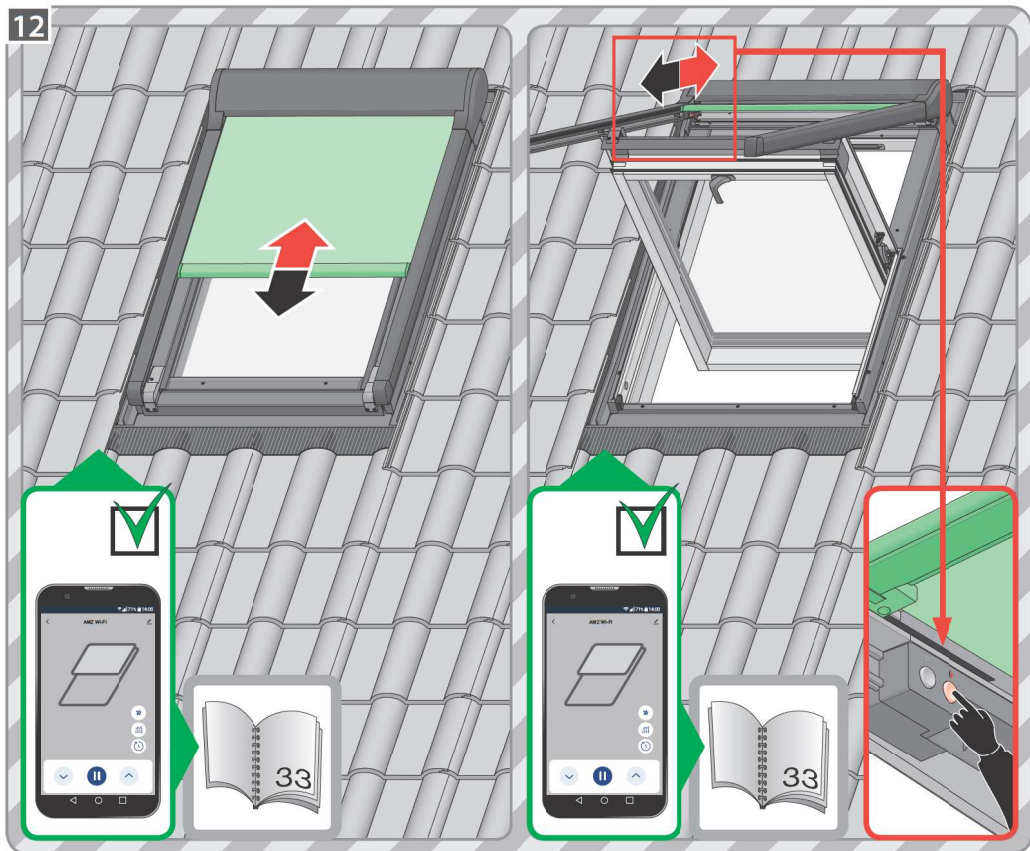

13

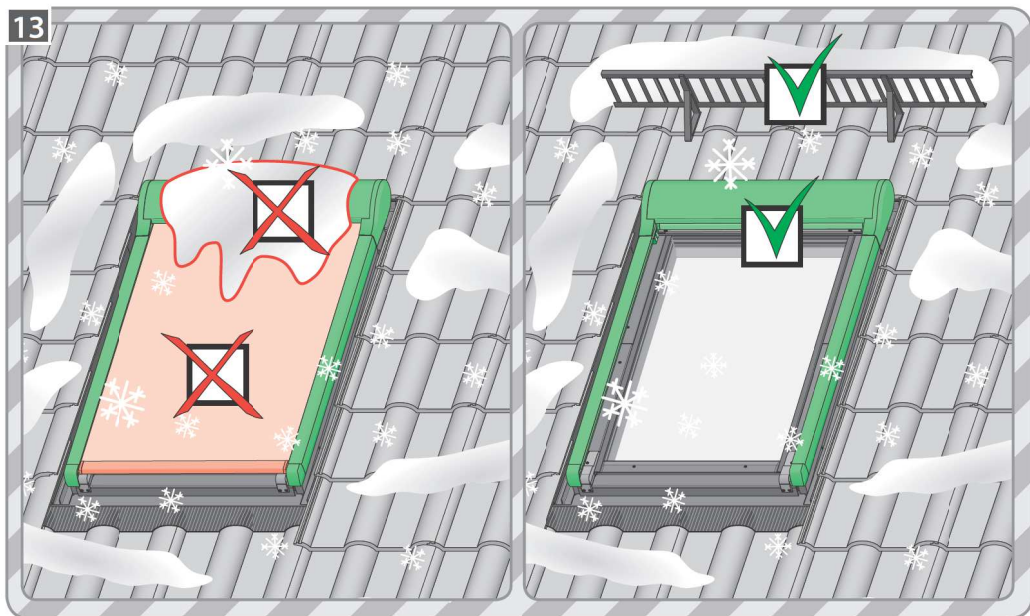

14

FTP-V, FTU-V, FTW-V, FPP-V, FTS,
FTS-V, FTT, PTP-V, PPP-V, PYP-V, PTP

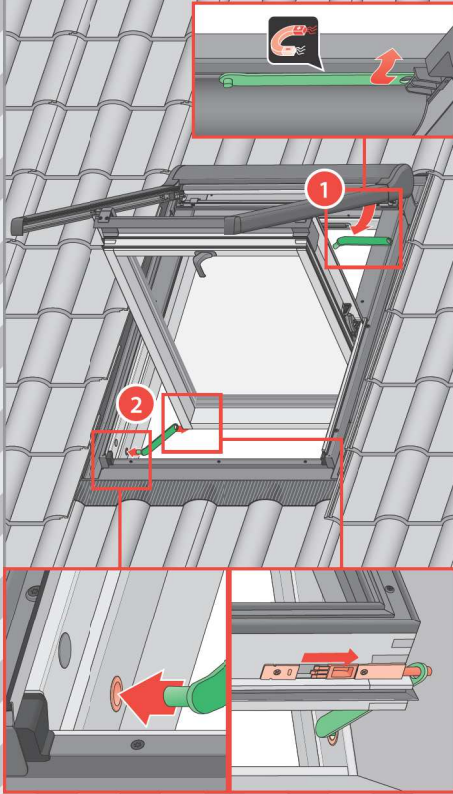

FYP-V, FDY-V, PYP-V



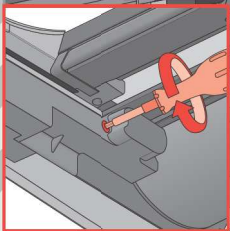
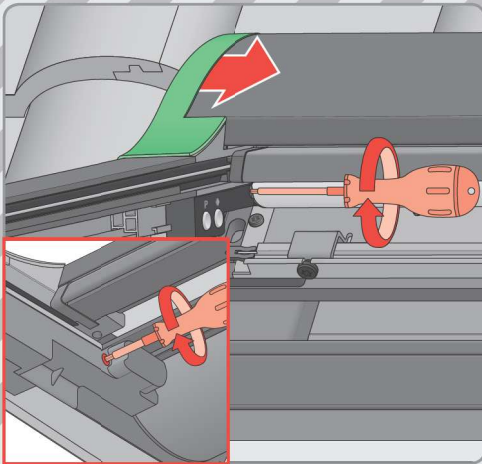
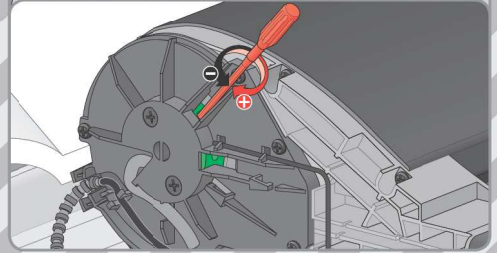
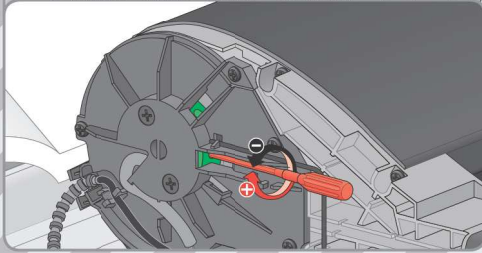
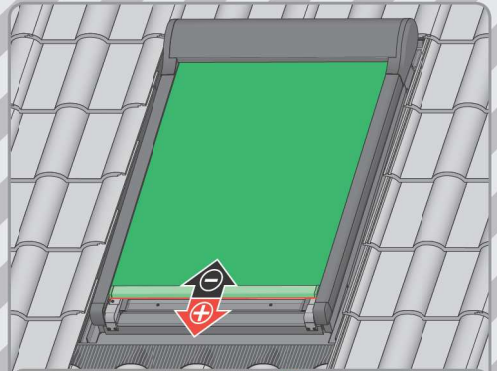
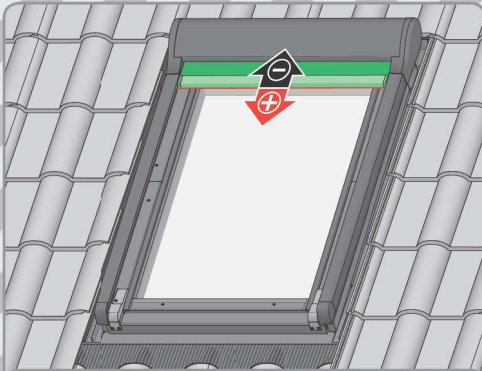
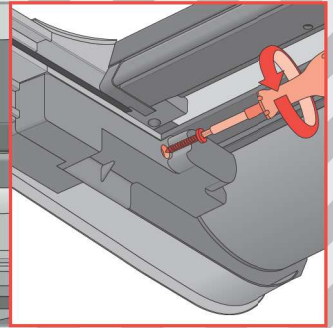
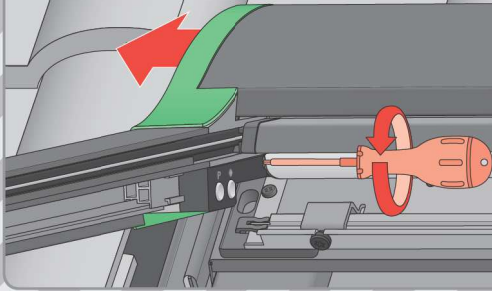

type WiFi

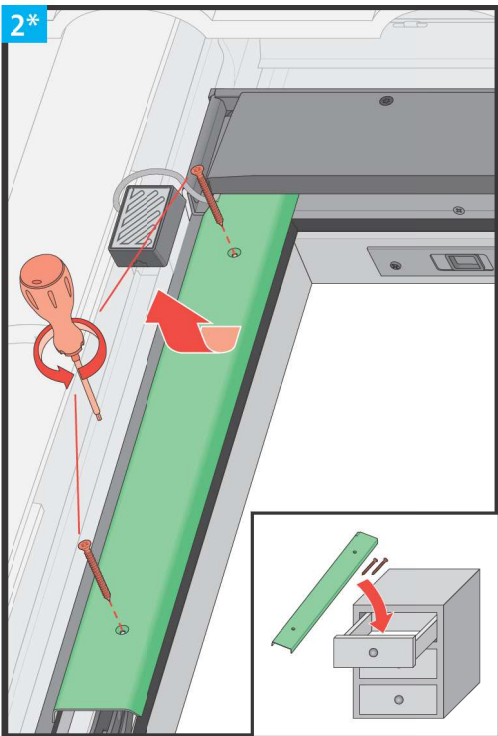
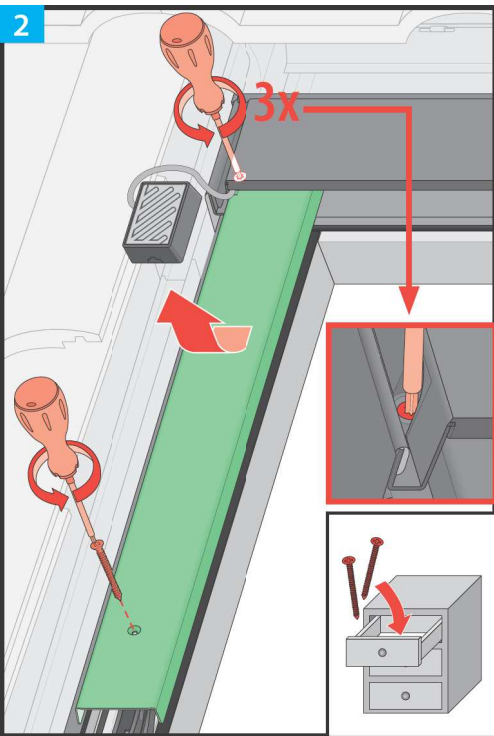
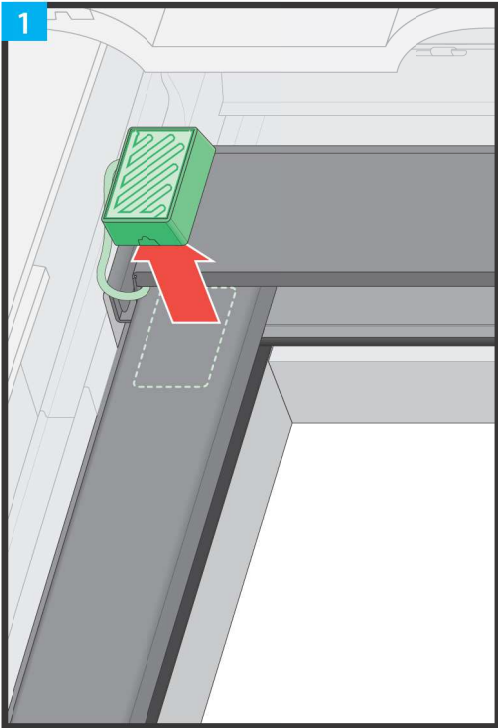
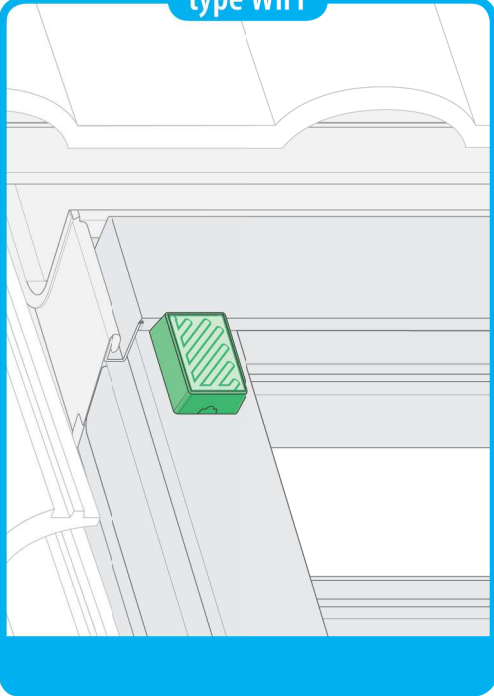

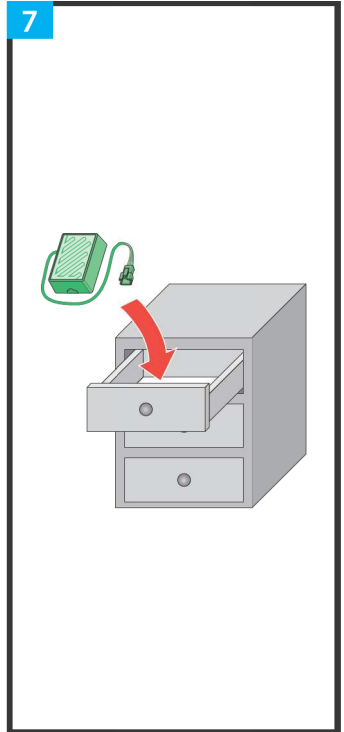
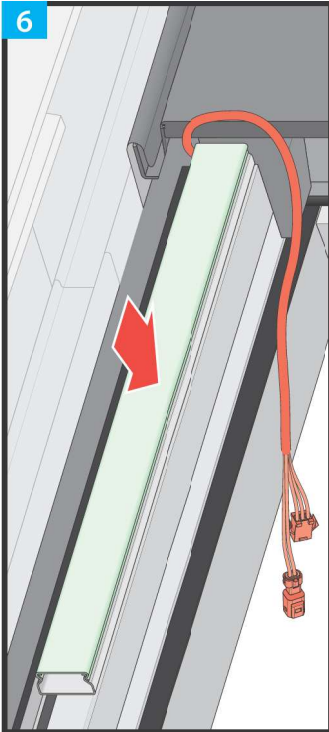
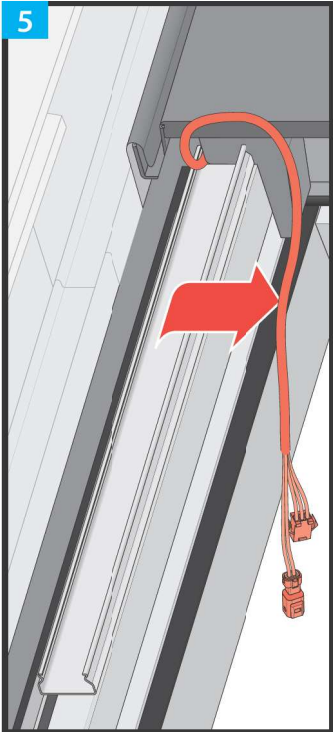
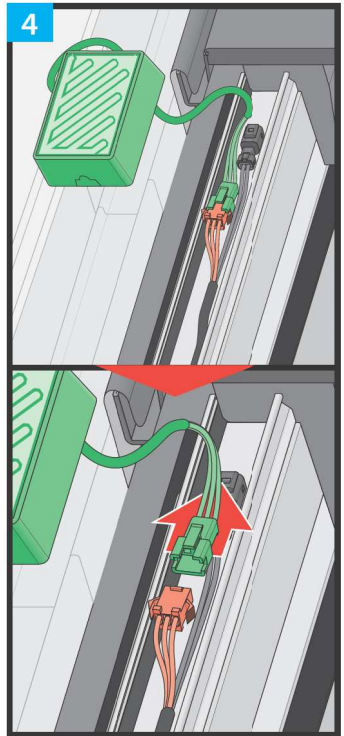
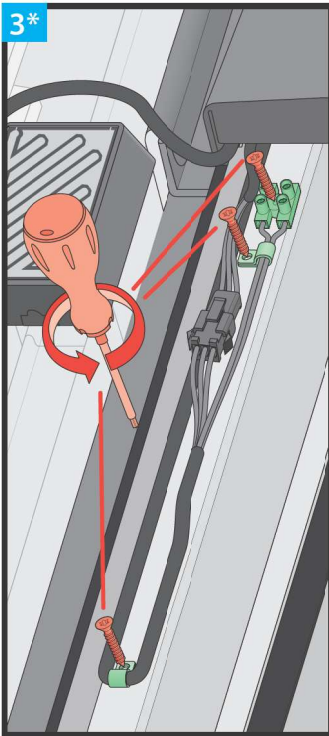
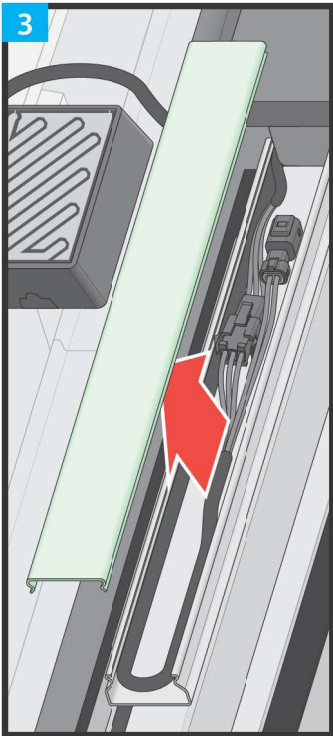

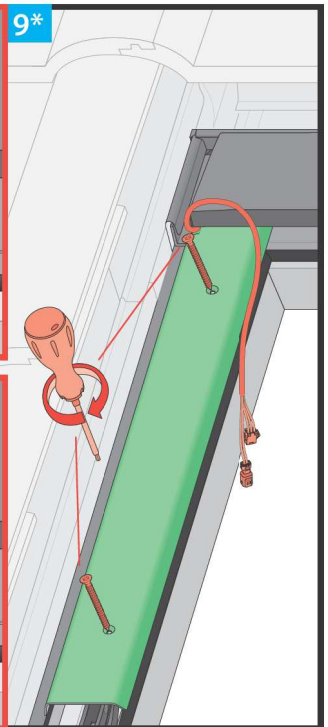
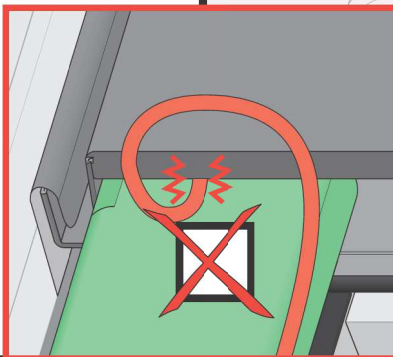
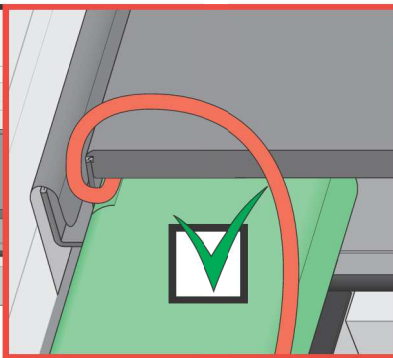
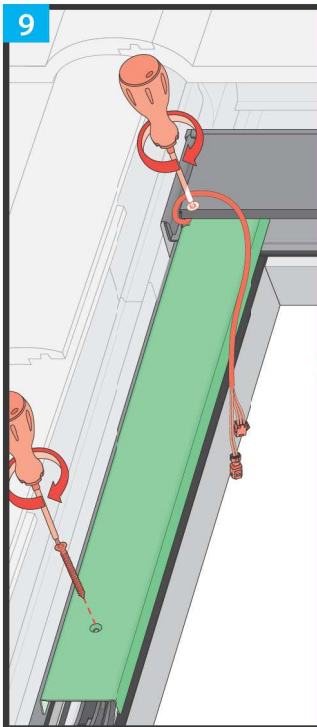
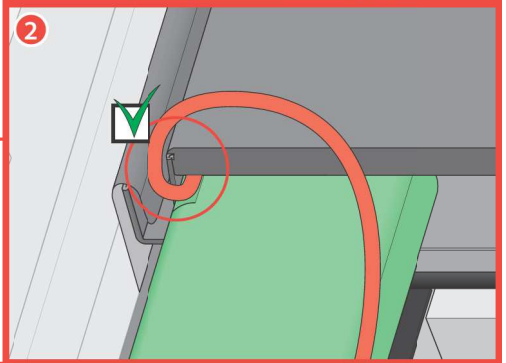
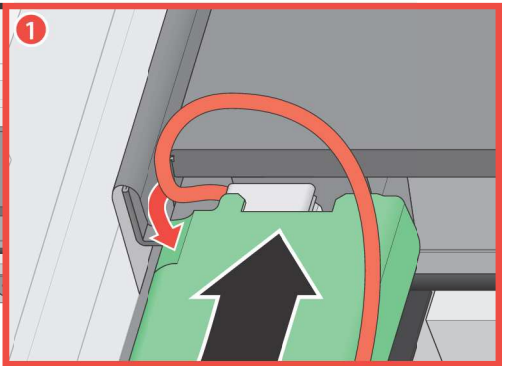
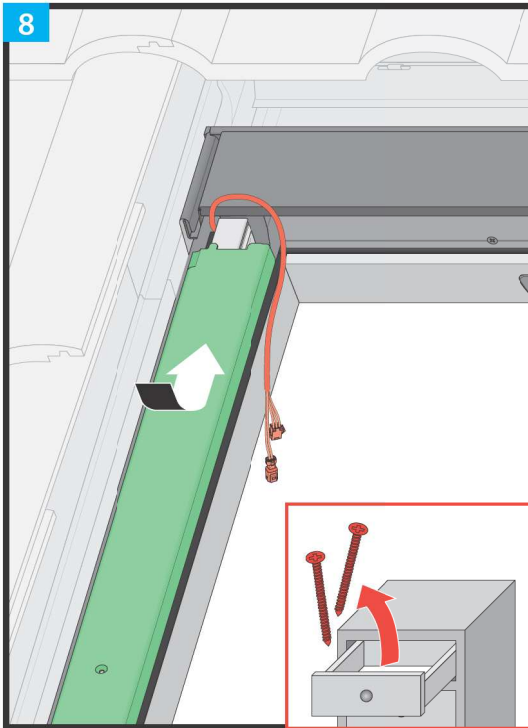

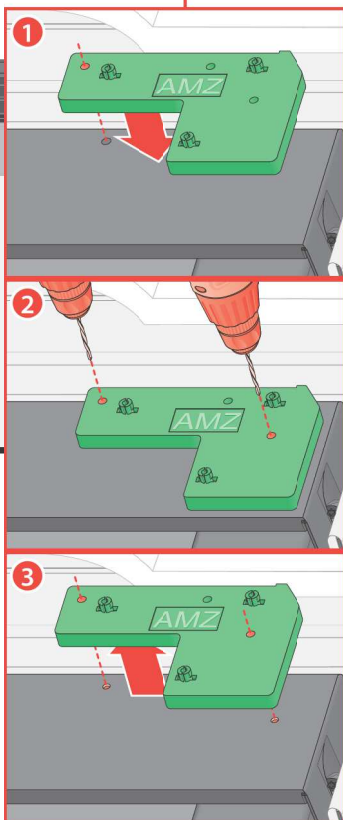
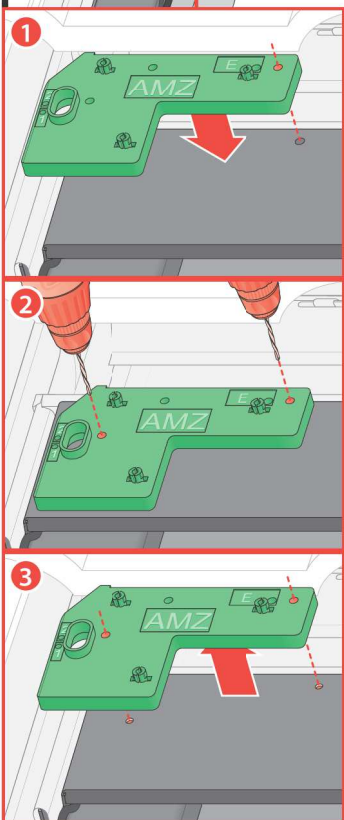
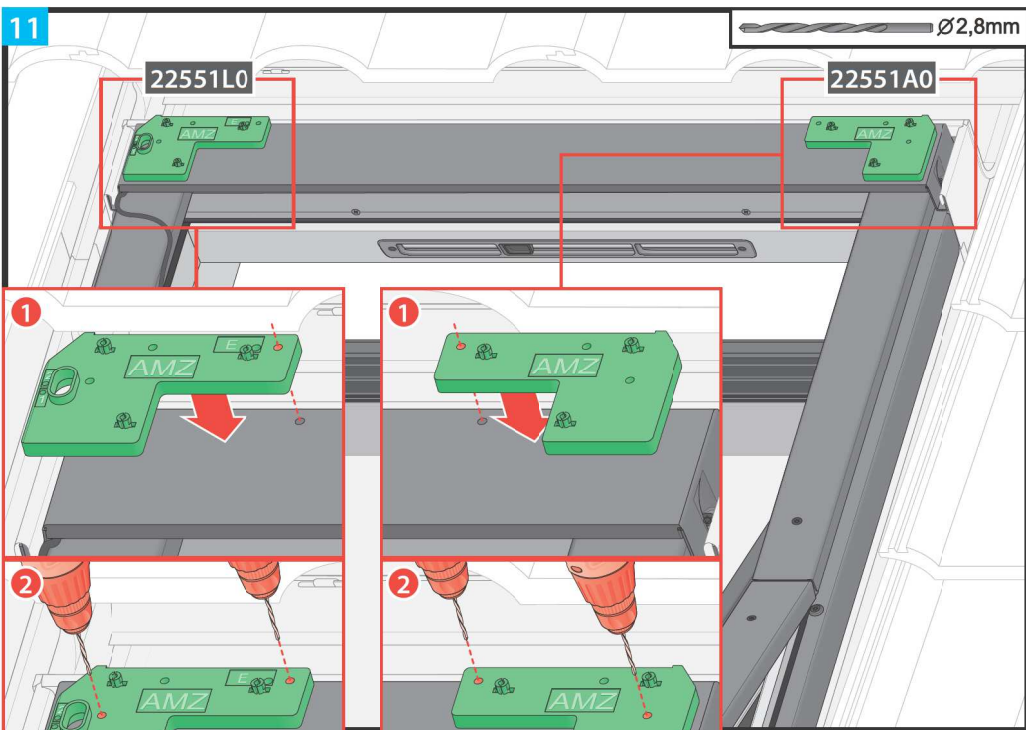
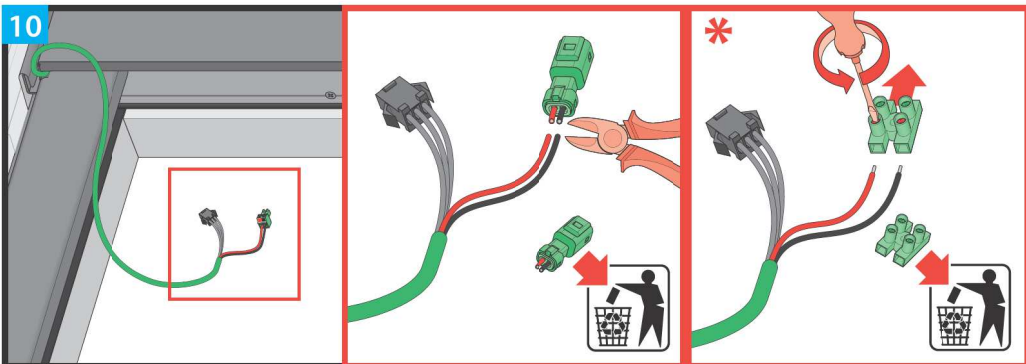

type WiFi

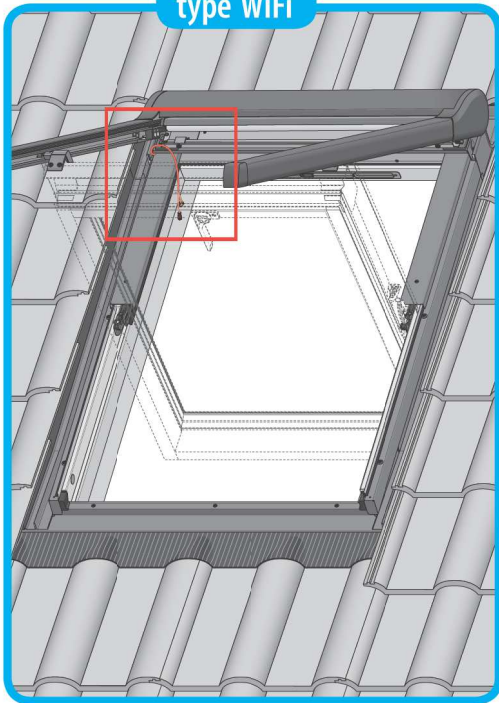

1

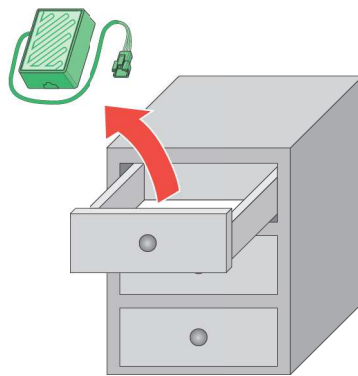

2

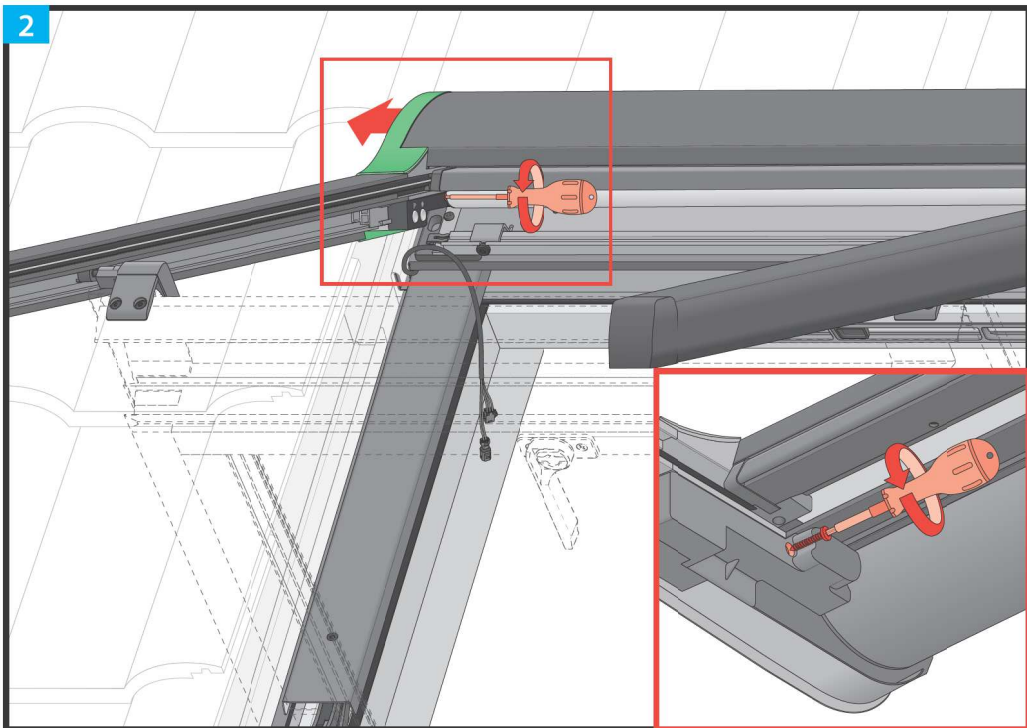

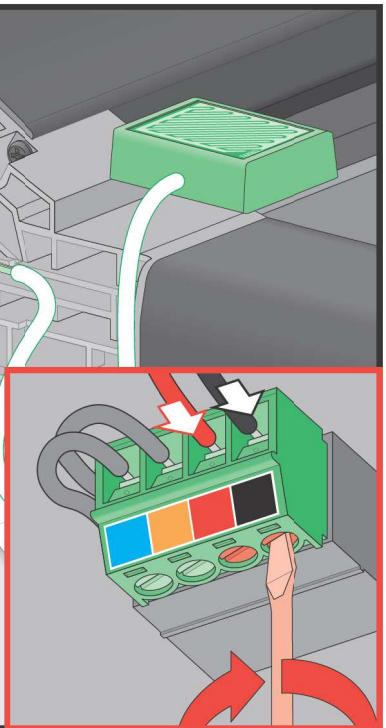
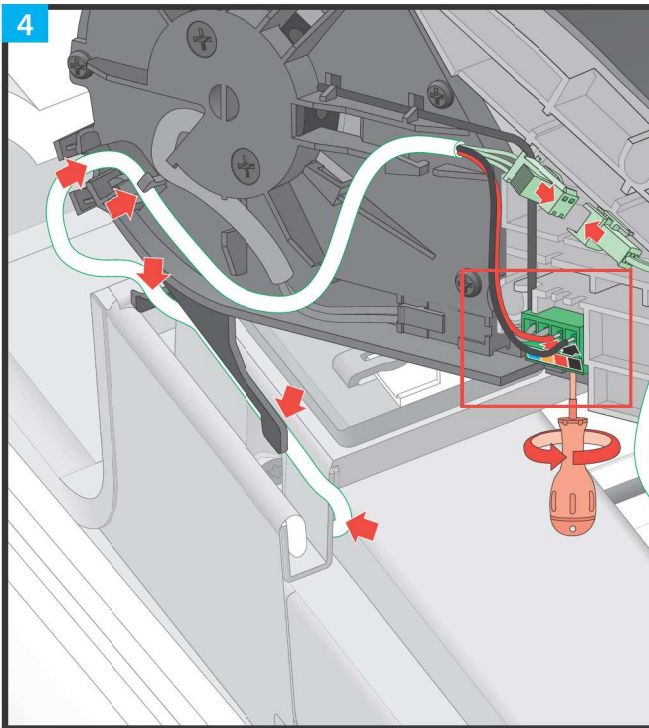
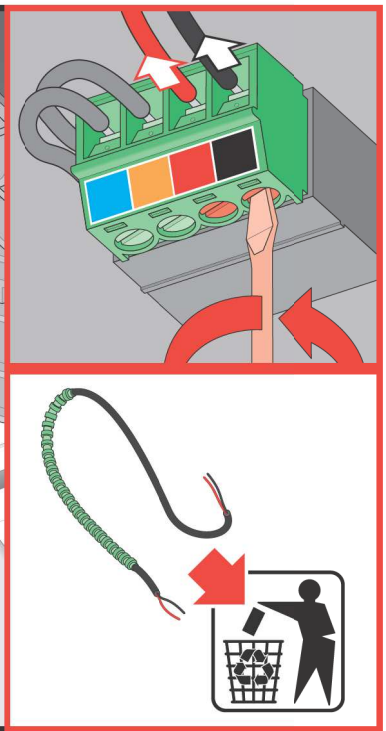
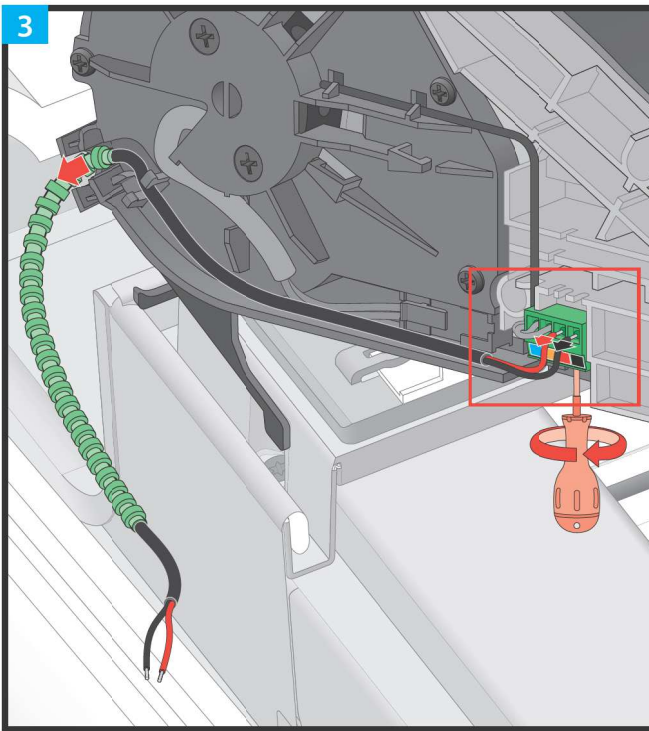

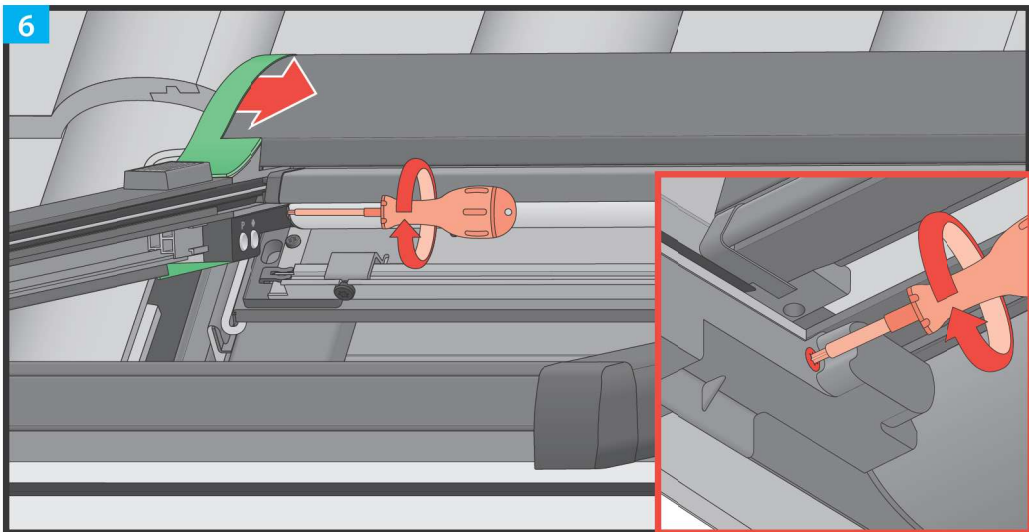
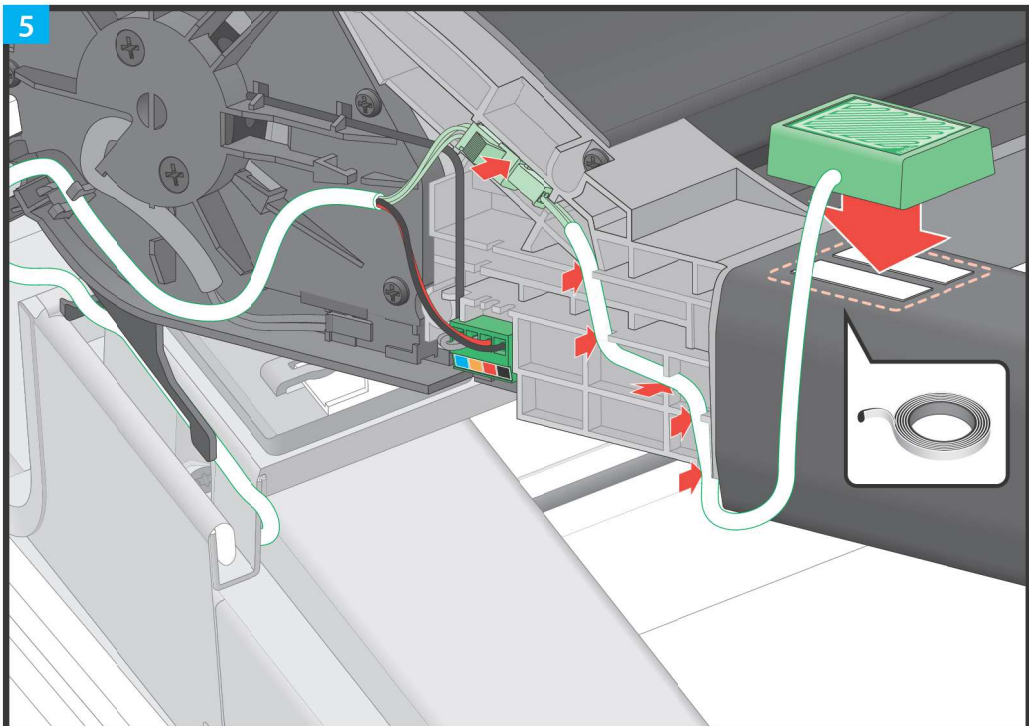

1



Fakro Smart
ANDROID



Fakro Smart
IOS

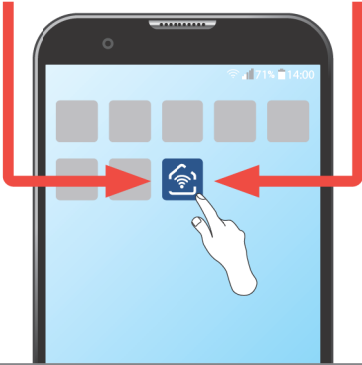

2

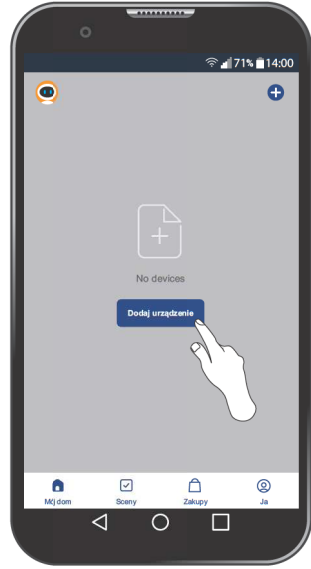

3

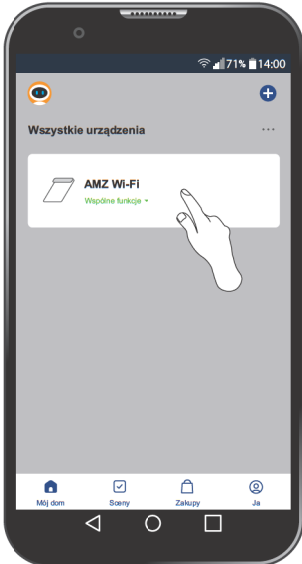

4



1 FYP-V, FDY-V, PYP-V

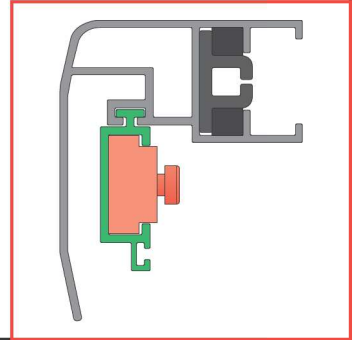
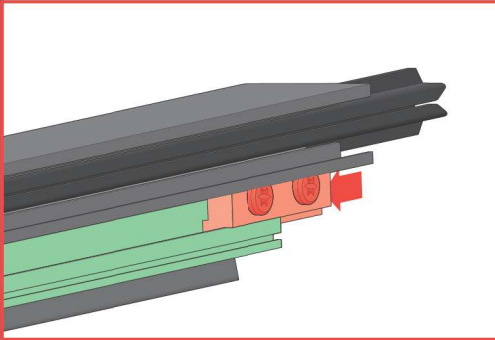
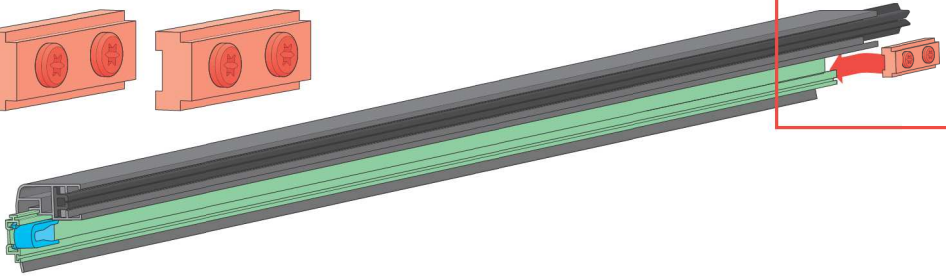
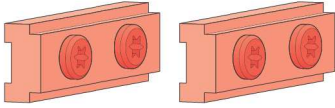

2

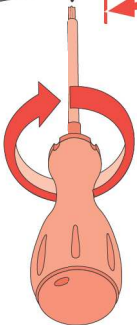
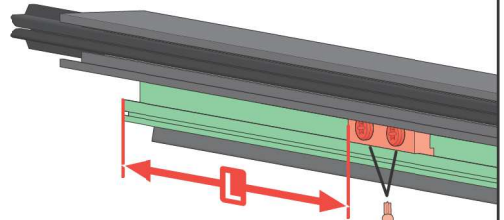
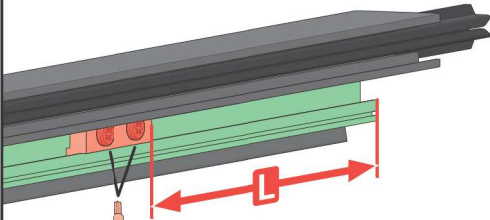

 H	L [mm]
98	295
118	350
140	550
160	550
180	600
206	660

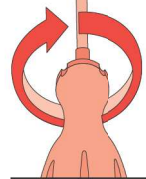

3c

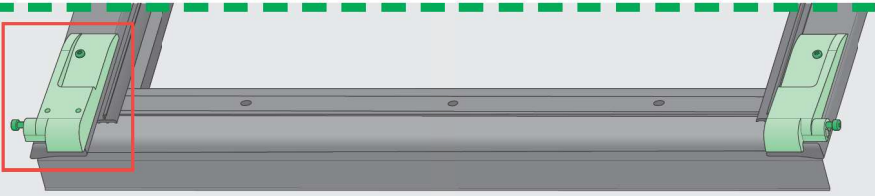

1

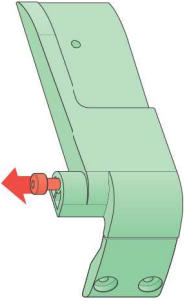

2

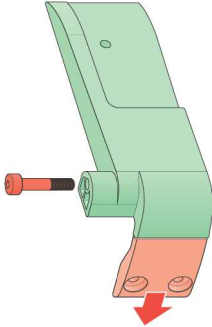

3

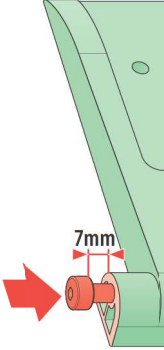

4

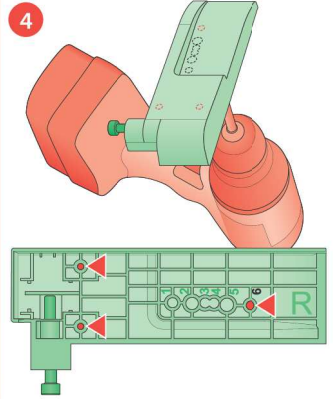

5

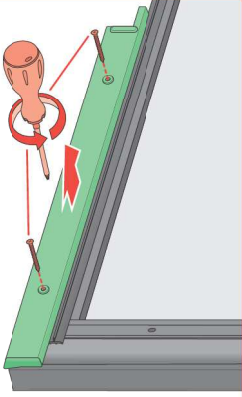

6

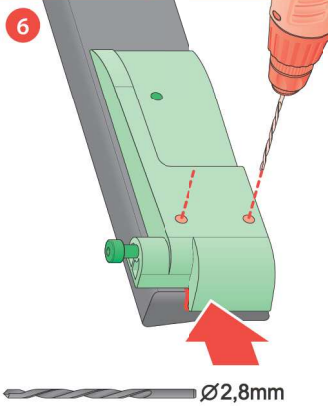

7

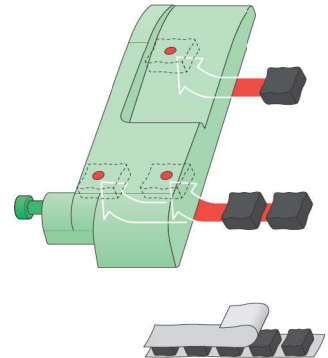

8

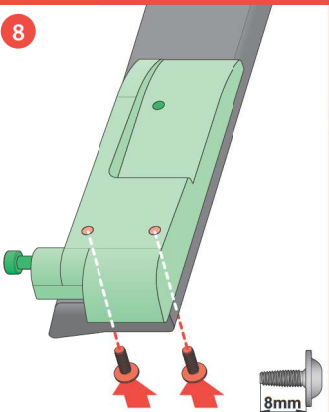

9

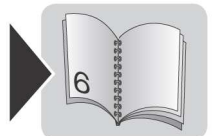
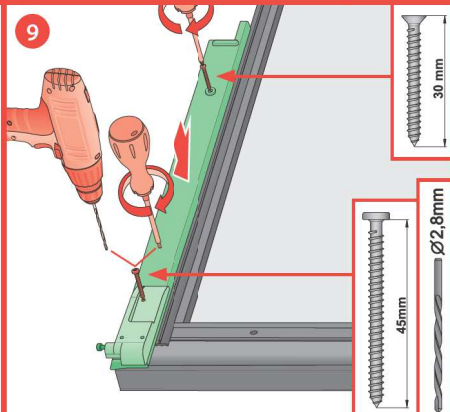

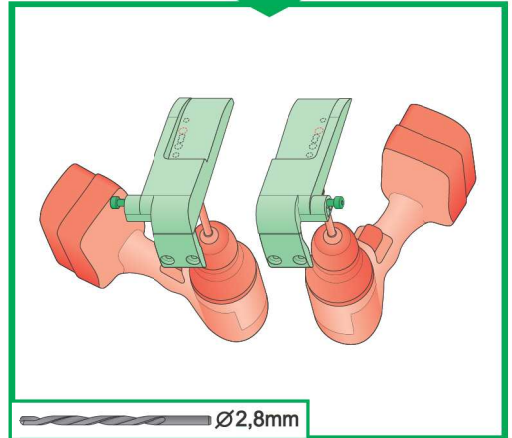
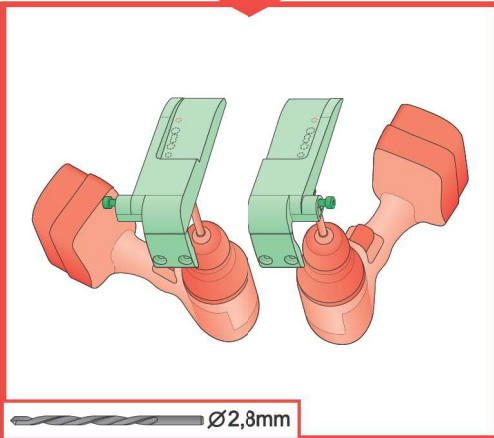
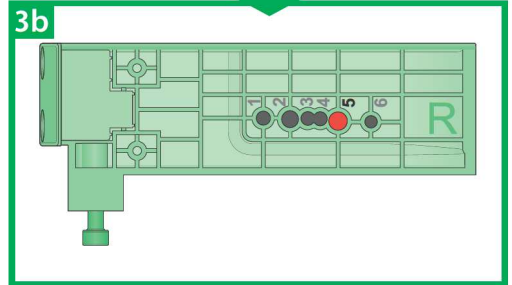
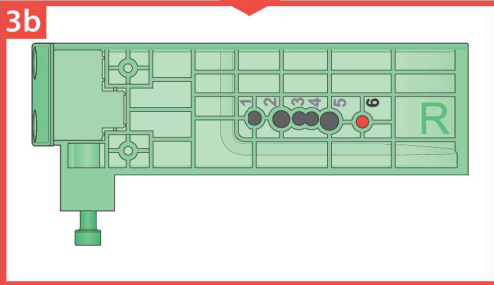
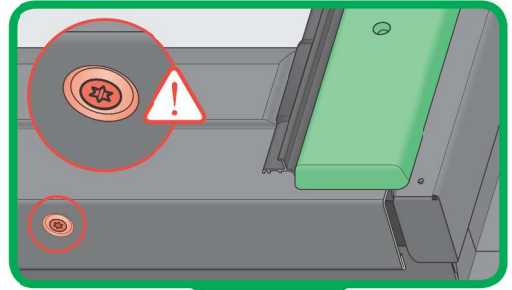
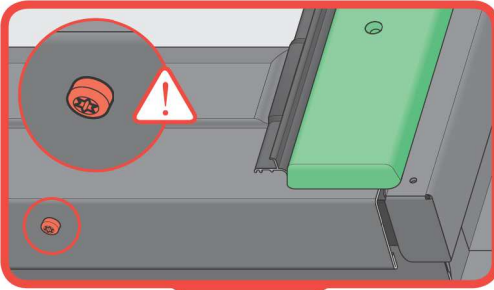
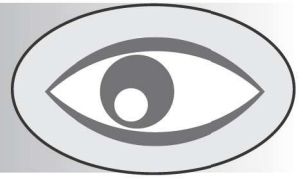

PL	Przed montażem należy zapoznać się z treścią instrukcji NC9S5 „INSTRUKCJA ORYGINALNA 2/3 Zasady montażu i użytkowania”.
1, 1*	Wyjąć zaczep zabezpieczający znajdujący się pod kasetą.
2	Zablokować skrzydło za pomocą zaczepu.
3a, 3b, 3c, 3d	Wykonać otwór w uchwytych dolnych w miejscu uzależnionym od typu okna a następnie przykręcić je do skrzydła okna.
4, 4*, 4a, 4b, 4c	Użyć podkładek montażowych w celu wykonania otworów w kapturze okna. Sposób montażu dobrać w zależności od typu okna. Sprawdzić, czy okno wyposażone jest w otwór pod przewód zasilający dodatek. W razie potrzeby wykonać otwór w kapturze a następnie umieścić w nim gumowy przepust.
5, 5a, 5b, 5c	Przykręcić podstawę montażową do kaptura okna za pomocą wkrętów dołączonych do zestawu montażowego. W razie potrzeby użyć dodatkowych podkładek.
6	Wsunąć przewód zasilający w otwór (type A, type X). Umieścić kasetę markizy na podstawie montażowej.
7	Przykręcić uchwyty markizy do podstawy montażowej.
8*	W przypadku montażu na oknach wysokoosiowych wykonać dodatkowe czynności zgodnie z instrukcją.
8a	Wsunąć narożnik do prowadnicy markizy.
8b	Połączyć zaczep prowadnicy z uchwytem dolnym markizy.
8c	Wsunąć prowadnicę boczną w korpus markizy.
8d	Przykręcić prowadnicę do korpusu.
9	Powtórzyć czynności 8a-8d dla prowadnicy lewej.
10	Umieścić zaczep zabezpieczający pod kasetą.
11	Podłączyć markizę do zasilania.
12	Sterować markizą za pomocą aplikacji lub przycisków na sterowniku.
13	Nie dopuszczać do nagromadzenia śniegu na markizie, w tym celu zaleca się stosowanie urządzeń zapobiegających zsuwaniu się śniegu na markizę.
14	Do zabezpieczenia okna w pozycji „do mycia” używać zaczepu zabezpieczającego.
15	W razie potrzeby przeprowadzić regulację pozycji końcowych markizy.

EN	Before installation, it is compulsory to read the NC9S5, ORIGINAL INSTRUCTIONS 2/3 Installation and user manual”.
1, 1*	Remove the safety catch under the cassette.
2	Lock the sash with the catch.
3a, 3b, 3c, 3d	Drill a hole in the bottom holders in the place depending on the window type and then screw them to the window sash.
4, 4*, 4a, 4b, 4c	Use mounting washers to drill holes in the window hood. Choose installation method depending on the window type. Check whether the window is equipped with a hole for the accessory's power cable. If required, drill a hole in the hood and then insert a rubber grommet into it.
5, 5a, 5b, 5c	Screw the mounting base to the window hood using the screws included in the mounting kit. If required, use additional washers.
6	Slide the power cable into the opening (type A or type X). Place the awning cassette on the mounting base.
7	Screw the awning holders to the mounting base.
8*	For installation on high-axis windows, perform additional steps according to the instructions.
8a	Slide the corner into the awning guide rail.
8b	Connect the guide rail catch with the awning bottom holder.
8c	Slide the side guide rail into the awning casing.
8d	Screw the guide rail to the casing.
9	Repeat steps 8a-8d for the left guide rail.
10	Place the safety catch under the cassette.
11	Connect the awning to the power supply.
12	Control the awning blind using the app or buttons on the controller.
13	Do not allow accumulation of snow on the awning. For this purpose it is recommended to use devices preventing snow from sliding onto the awning.
14	Use the safety catch to secure the window in the position for cleaning.
15	If required, adjust the end positions of the awning.

0 [cm] 1 2 3 4 5 6 7 8 9 10 11 12

BG	Производител и Продавач не носят отговорност за неспазване на съответните закони, строителни норми и изисквания за безопасност от ползването на продукта, архитекта, монтажника или собственика на сградата.
CZ	Uživatelé ani prodejci nenesou odpovědnost za neudržení příslušných právních zákonů, stavebních předpisů a bezpečnostních požadavků užíváním výrobku, architektem, montážním nebo vlastníkem budovy.
DE	Hersteller und Verkäufer übernehmen keine Haftung für Nichtbeachtung entsprechender Rechts- und Bauvorschriften sowie Sicherheitsanforderungen seitens Produktbenutzer, Architekten, Monteurs oder Gebäudebesitzer.
ES	El fabricante y el vendedor no tienen ninguna responsabilidad por el incumplimiento de la ley vigente, normas de construcción y exigencias de seguridad por parte del usuario del producto, arquitecto, instalador o el propietario del edificio.
FR	Le fabricant et le vendeur ne prend aucune responsabilité de ne pas respecter les lois applicables, les règlements sur les bâtiments et les exigences de sécurité par l'utilisateur du produit, l'architecte, l'installateur ou le propriétaire du bâtiment.
GB	Manufacturer and Seller shall bear no liability for failure to comply with the applicable laws, building codes and safety requirements by the user of the product, architect, fitter or owner of the building.
HU	A gyártó és a forgalmazó nem vállal semmilyen felelősséget a vonatkozó törvények, építési és biztonsági előírások tiszteletlen megsértéséért, építésszerelő, beszállító vagy épülettulajnos által be nem tartásáért.

IT	Il Produttore e il Rivenditore non potranno essere ritenuti responsabili per il mancato rispetto, da parte dell'utente del prodotto, dell'architetto, dell'installatore o del proprietario dell'edificio, delle leggi vigenti, nonché dei regolamenti edilizi e di quelli relativi alla sicurezza.
NL	De fabrikant en verkoper zijn niet aansprakelijk voor gevolgen bij het niet opvolgen van toepasselijke wetten, bouwvoorschriften en veiligheidsvoorschriften en door de gebruiker van het product, de architect, de installateur of de eigenaar van het gebouw.
PL	Producent i Sprzedawca nie ponoszą żadnej odpowiedzialności za nieprzestrzeganie stosownych przepisów prawa, przepisów budowlanych i wymogów bezpieczeństwa przez użytkowników produktu, architekta, montażystę lub właściciela budynku.
PT	O fabricante e o vendedor não tem nenhuma responsabilidade pelo o não cumprimento da lei, códigos de construção e as exigências de segurança por parte do usuário do produto, arquiteto, instalador ou proprietário do edifício.
RO	Nu producătorul, nici distribuitorul nu îl vor răspunde pentru nerespectarea legilor în vigoare a legilor din domeniul construcțiilor sau a măsurilor de siguranță impuse utilizatorilor produsului, arhitecților, montajorilor sau proprietarilor clădirii.
RU	В случае несоблюдения архитектором, монтажником или владельцем здания строительных правил и норм безопасности ответственность производителю и продавцу снимается.
SK	Vyniká z predaja a nenasú žiadnu zodpovednosť za nedodržanie príslušných ustanovení zákona, stavebných predpisov a bezpečnostných požiadaviek užívateľom výrobku, architektom, montážom alebo majiteľom objektu.