

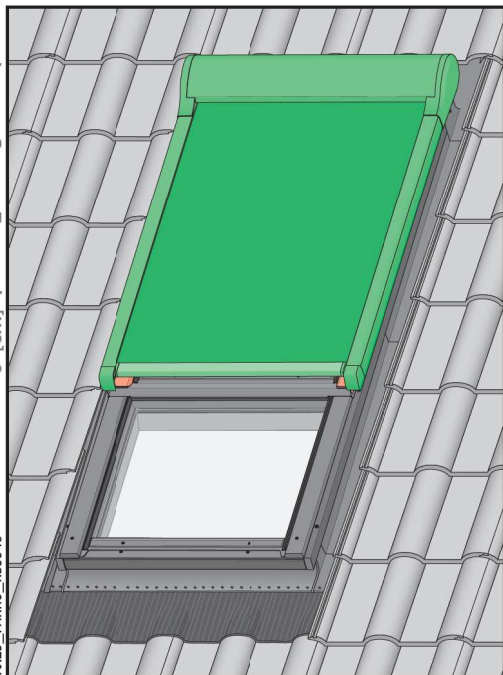

AMZ Z-Wave (FDY, FGH)



NC 99P_AMZ-Z-Wave (M) (FDY, FGH)_23.10.23_FAKRO_KB3348



min 40mm

- EN Before installation, it is compulsory to read the NC99P_ORIGINAL INSTRUCTIONS 2/3 Installation and user manual".
- 1 Remove the safety catch under the cassette.
 - 2 Lock the sash with the catch.
 - 3, 3a, 3b, 3c Select the mounting base depending on the window hood type and then fix it using the screws included in the awning installation kit.
 - 4 Check whether the window is equipped with an opening for the power cable for the accessory.
 - 5 Make an opening in the hood and then place a



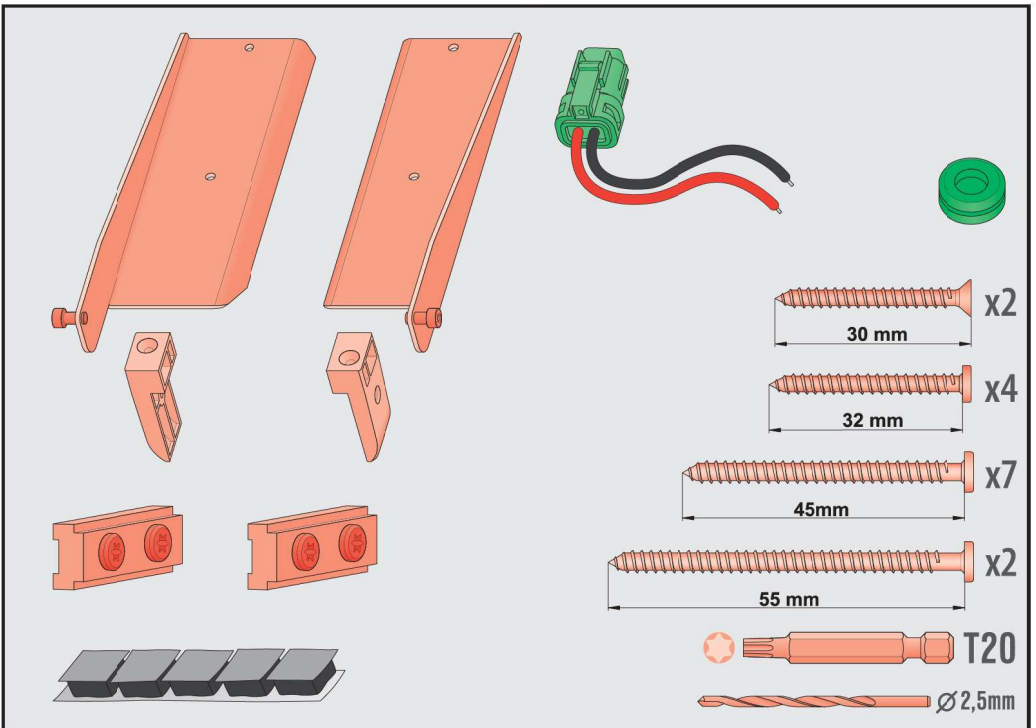
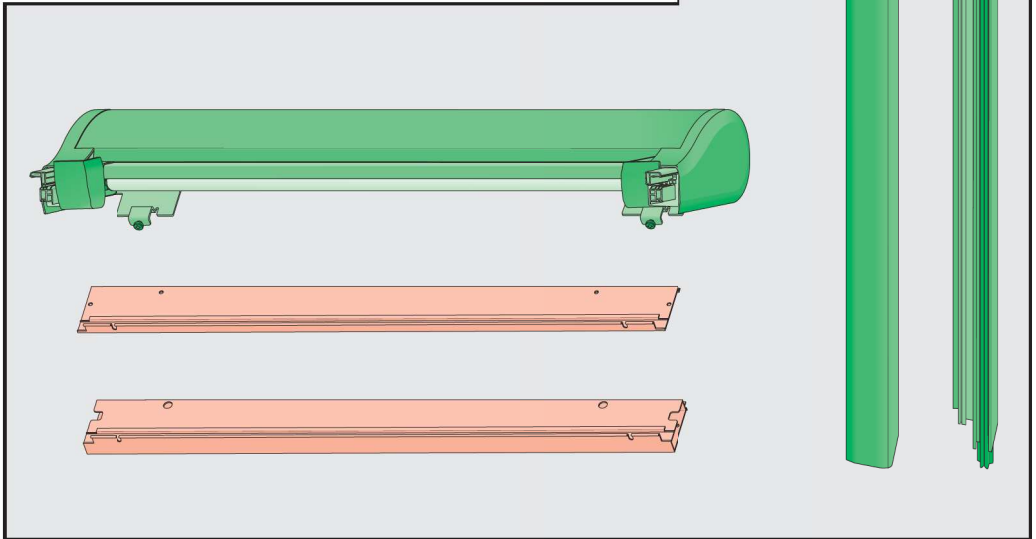
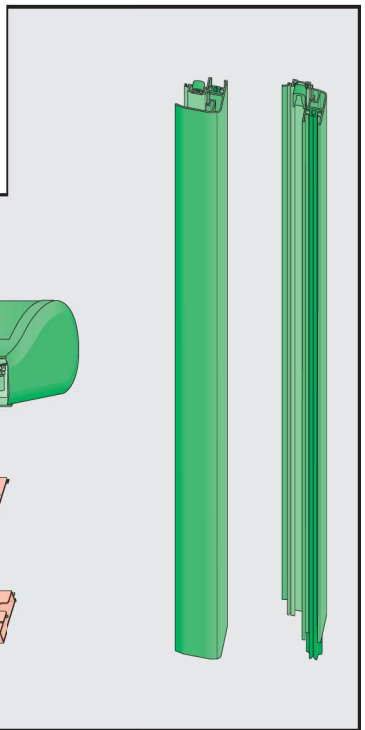

1a FYP-V, FDY-V, PYP-V

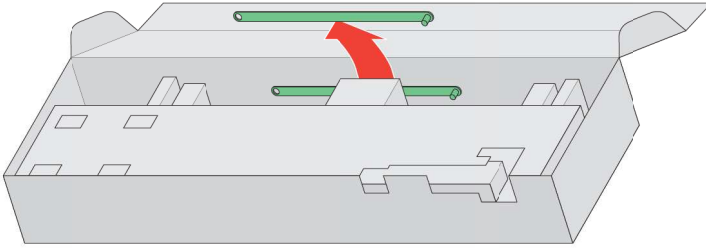

1b FTP-V, FTU-V, FTW-V, FPP-V, FTS, FTS-V, FTT, PTP-V, PPP-V, PTP

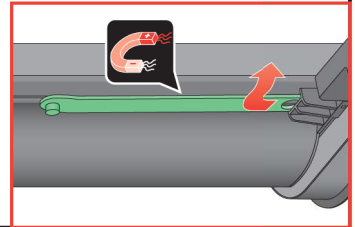

2

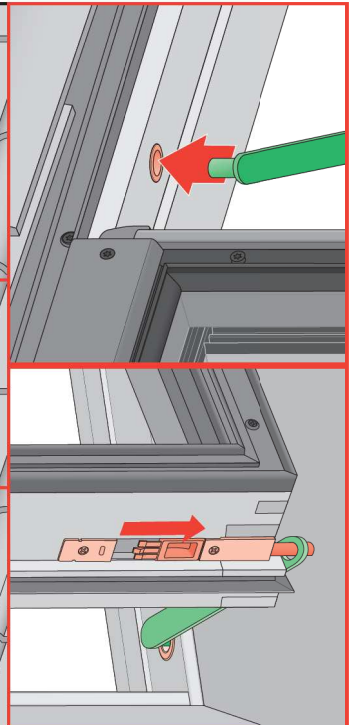
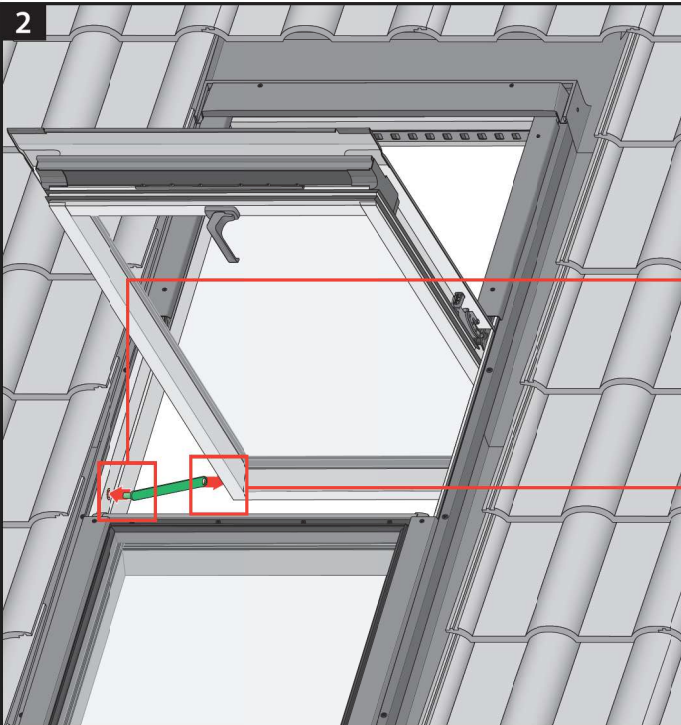

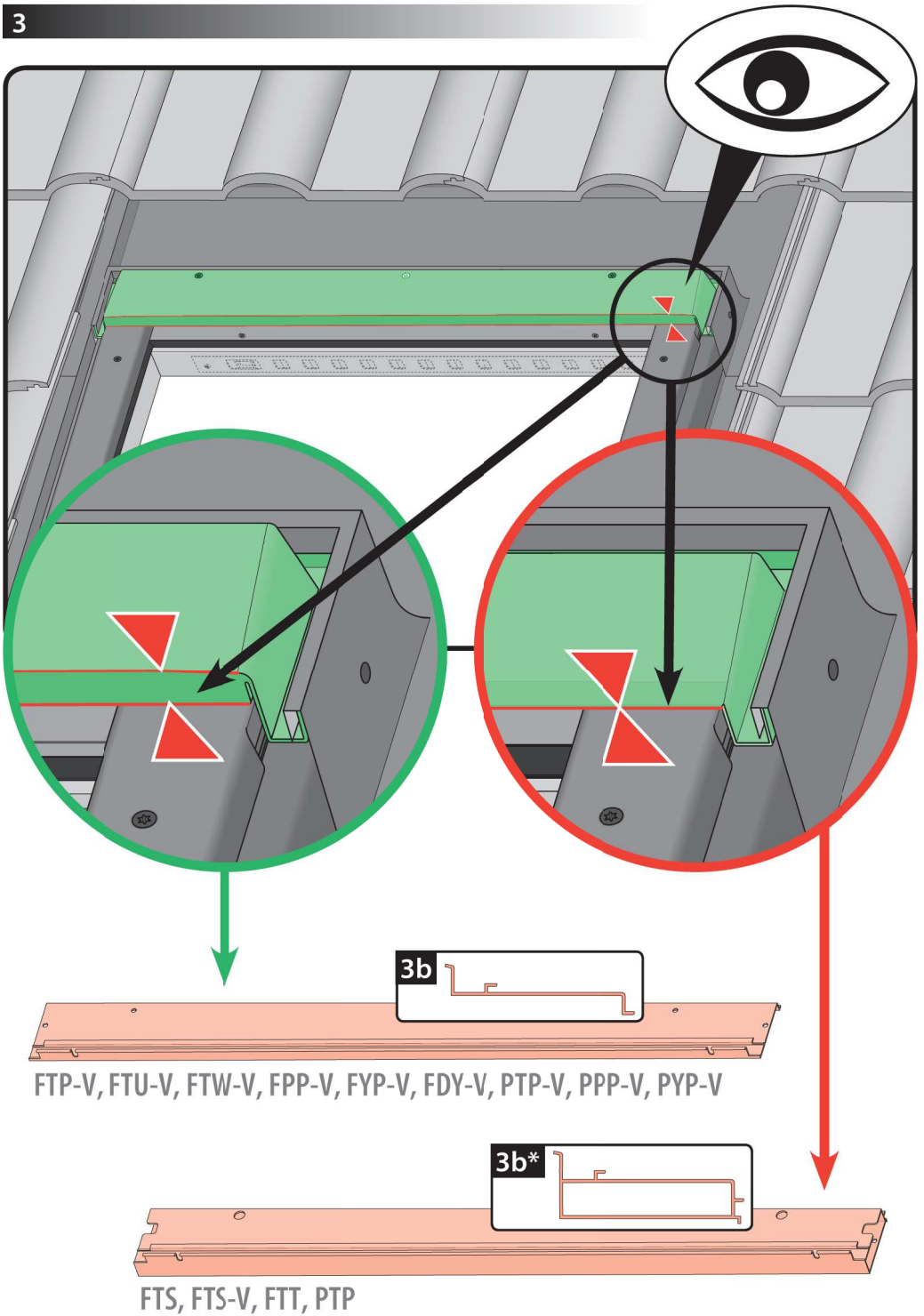

3a

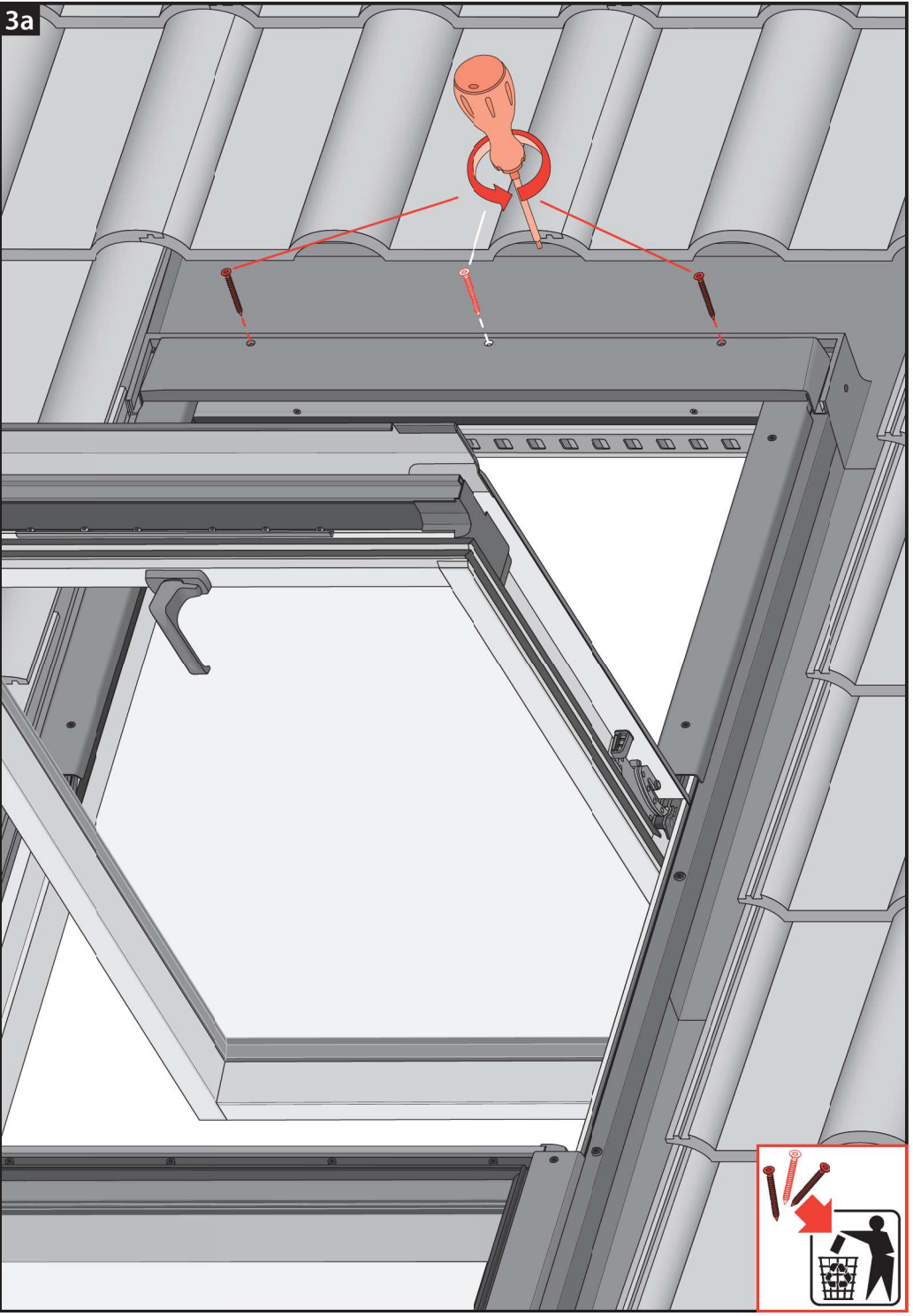

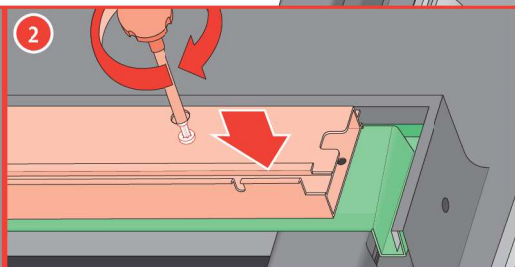
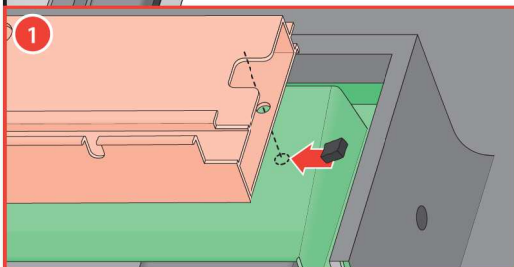
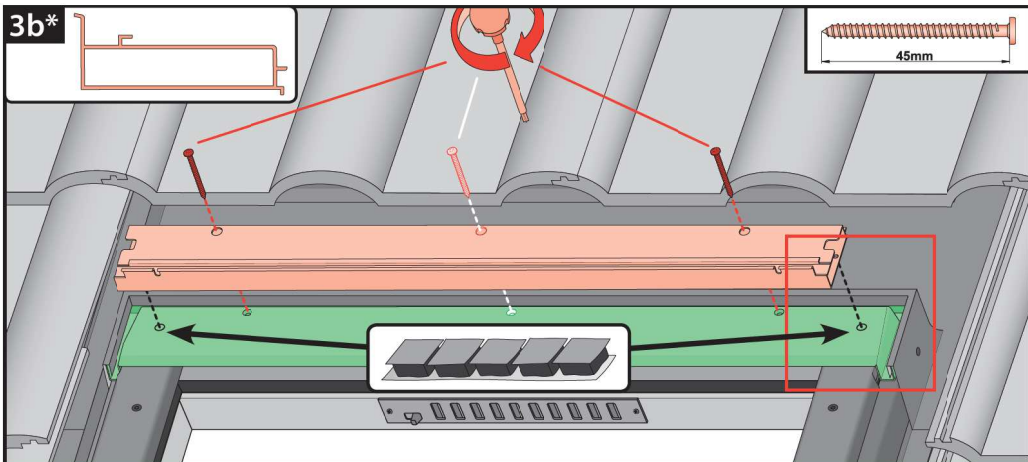
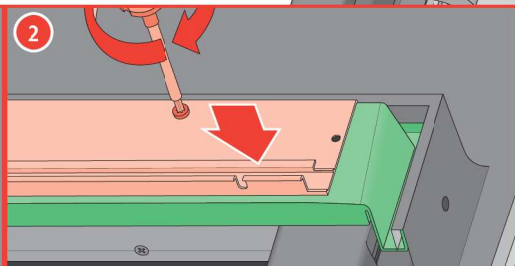
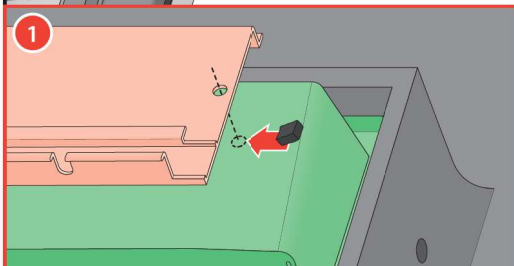
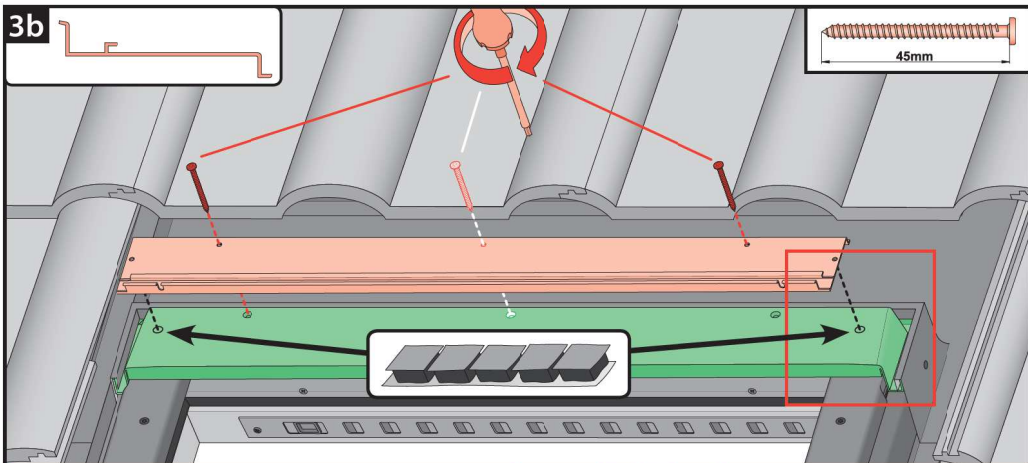

3c

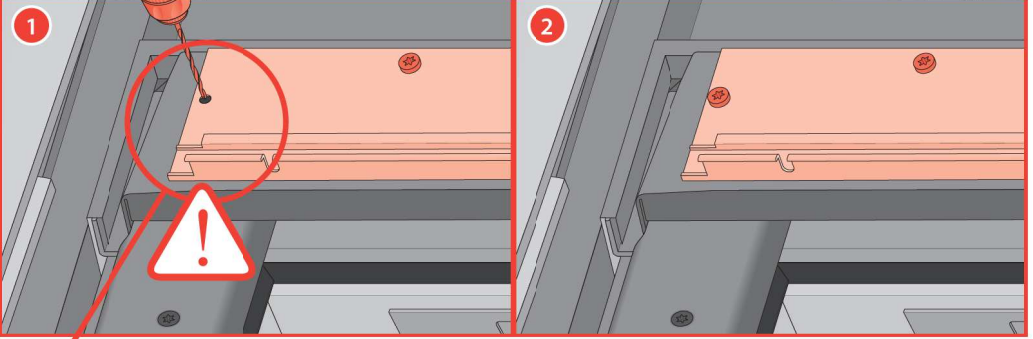
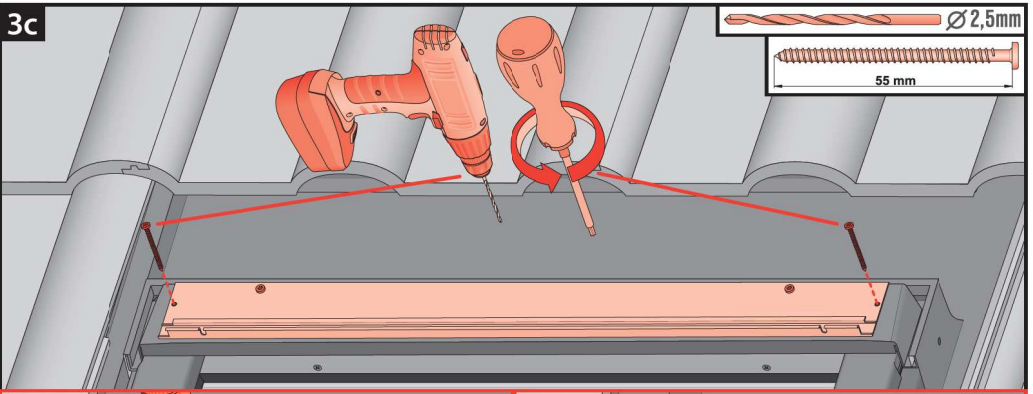
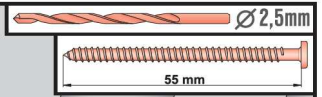

FT.. ELECTRO 24
FT.. Z-Wave

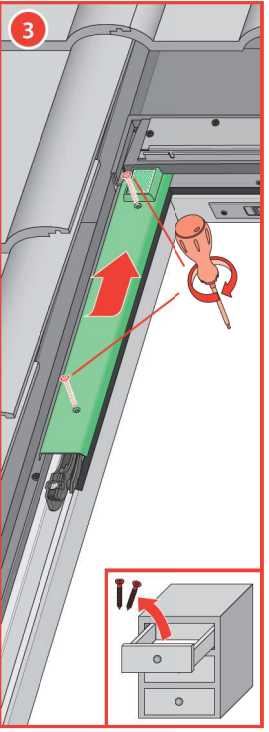
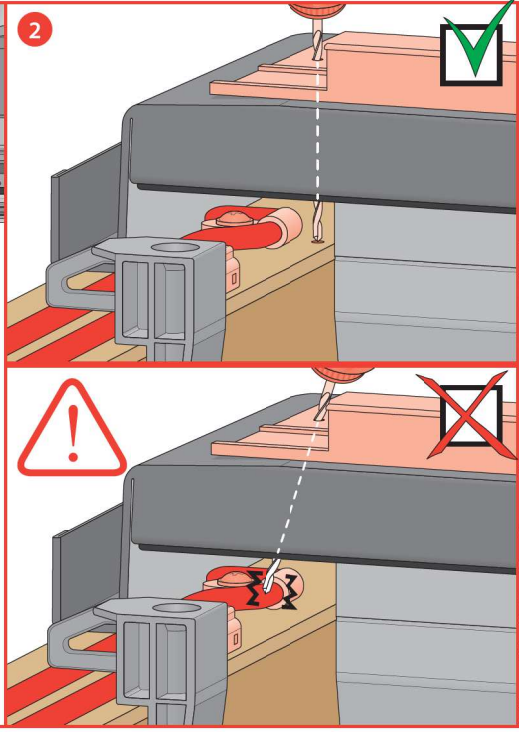
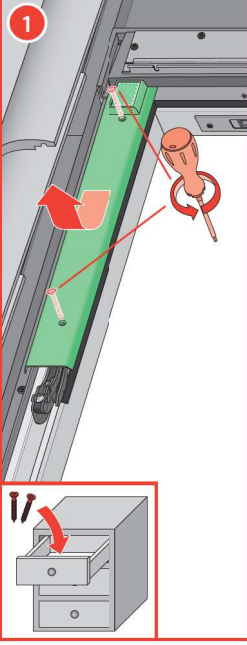

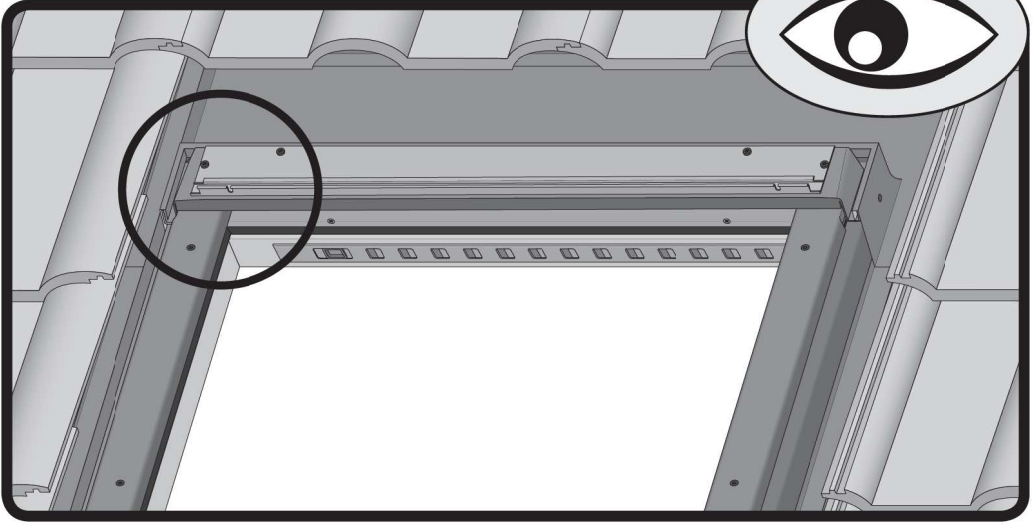

type A

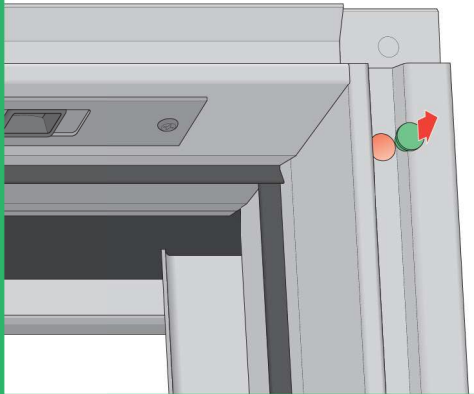

FTS, FTS-V, FTP, FTP-V, FYP, FYP-V
 FTT, FDY-V, FPP preSelect 2
 PTP, PTP-V, PYP, PYP-V



type B

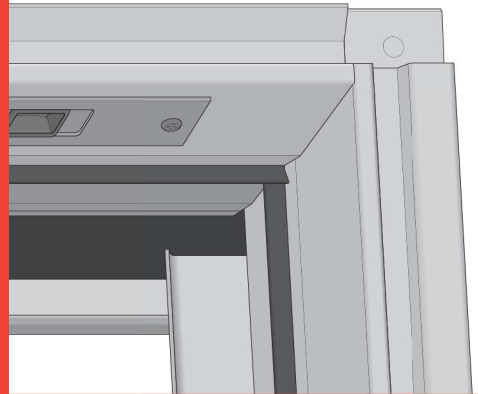

FTS, FTS-V, FTP, FTP-V, FYP, FYP-V
 FTT, FDY-V, FPP preSelect
 PTP, PTP-V, PYP, PYP-V



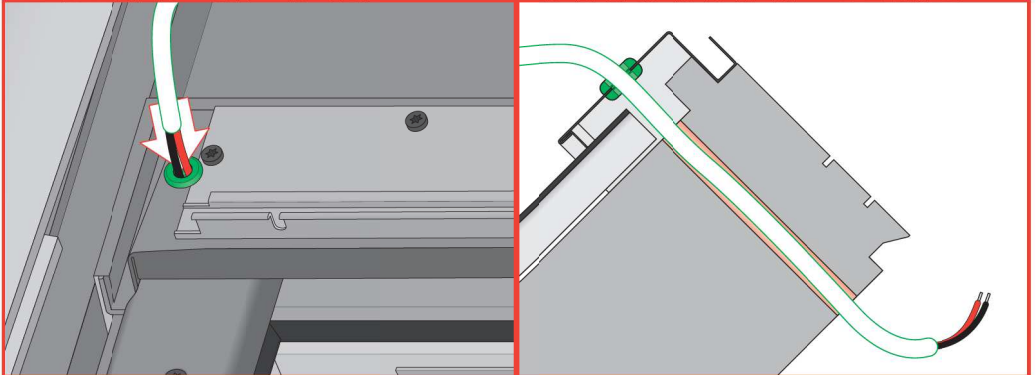
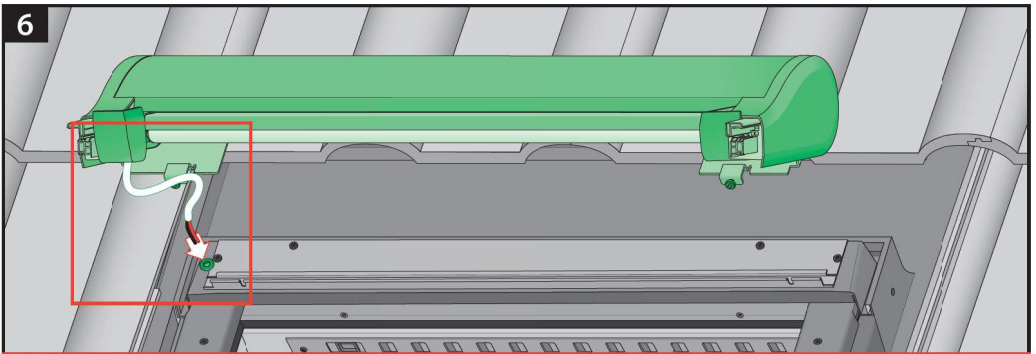
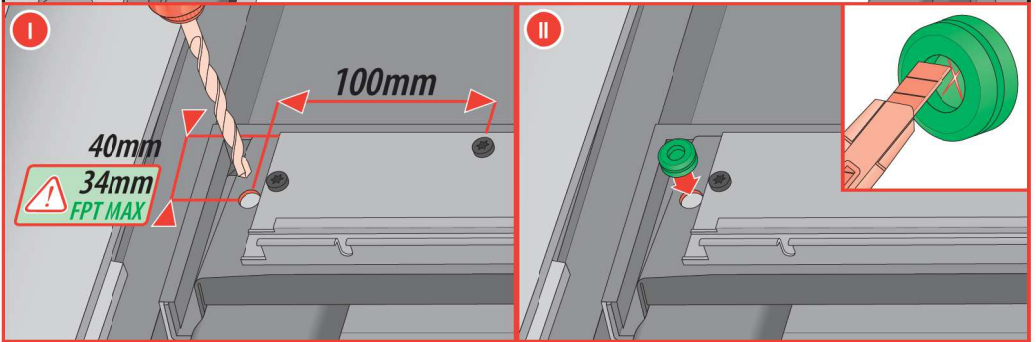
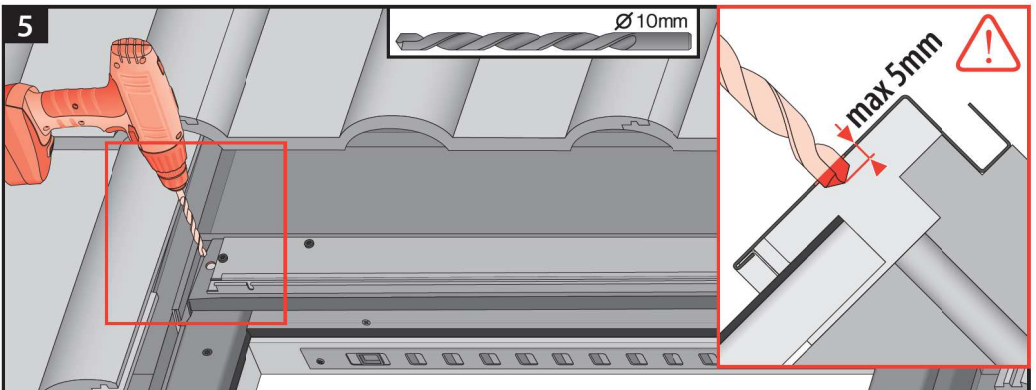

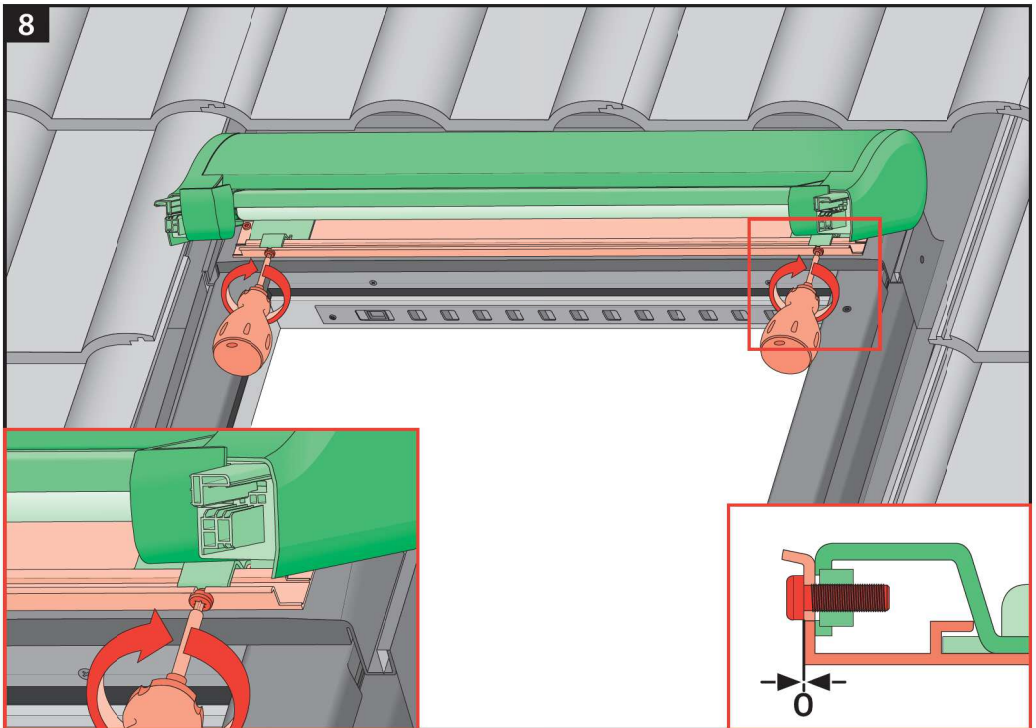
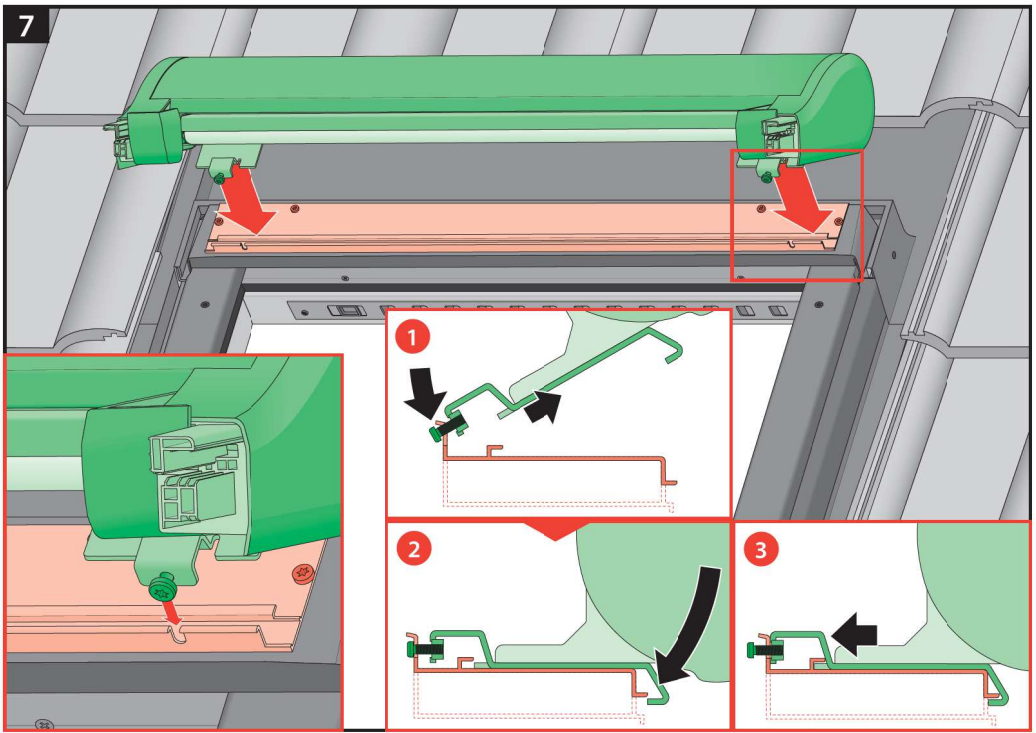

10*



FYP-V
FDY-V
PYP-V

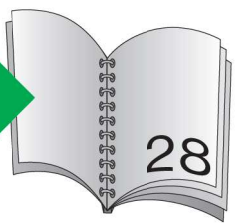
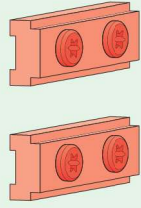

10a

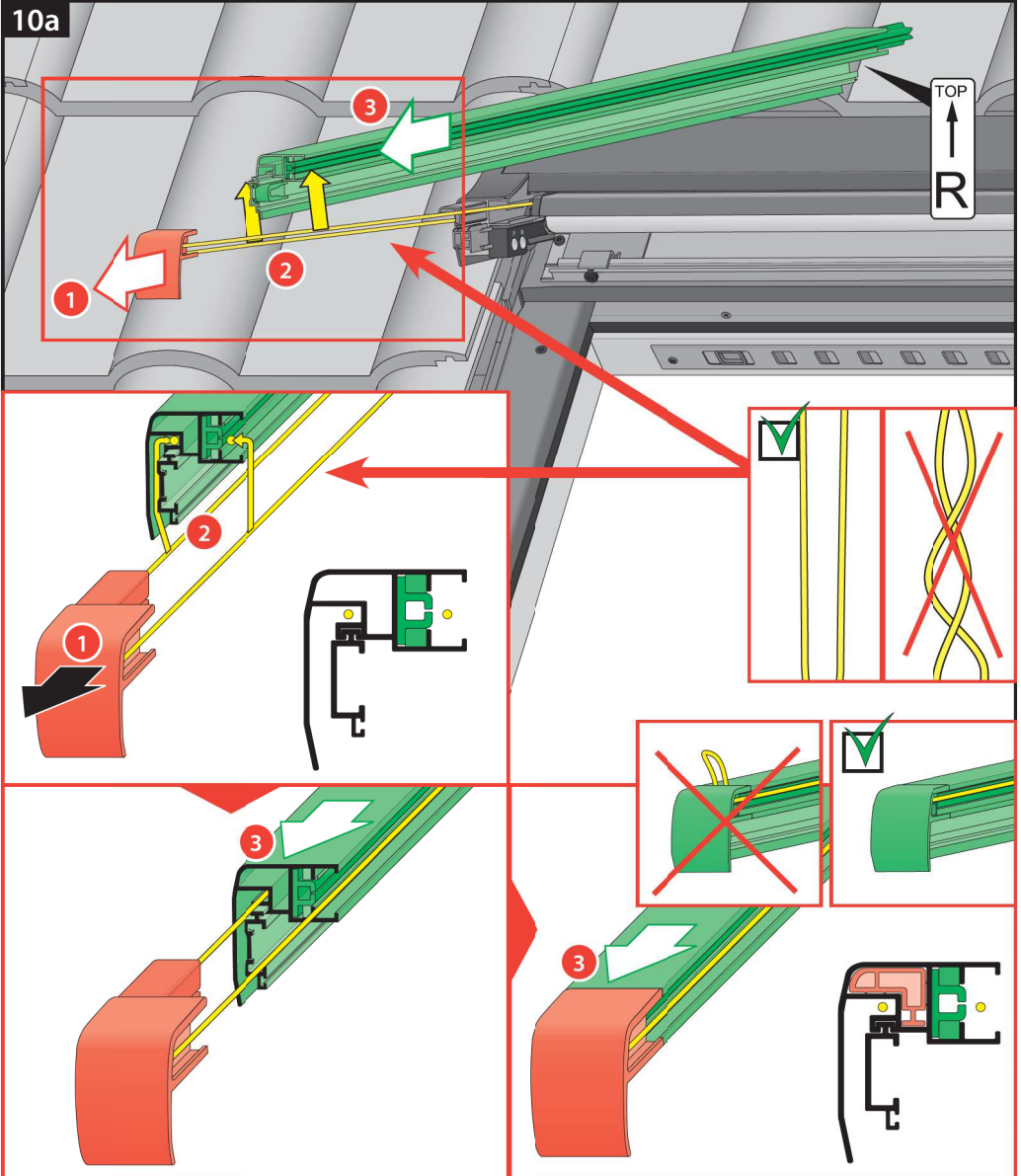

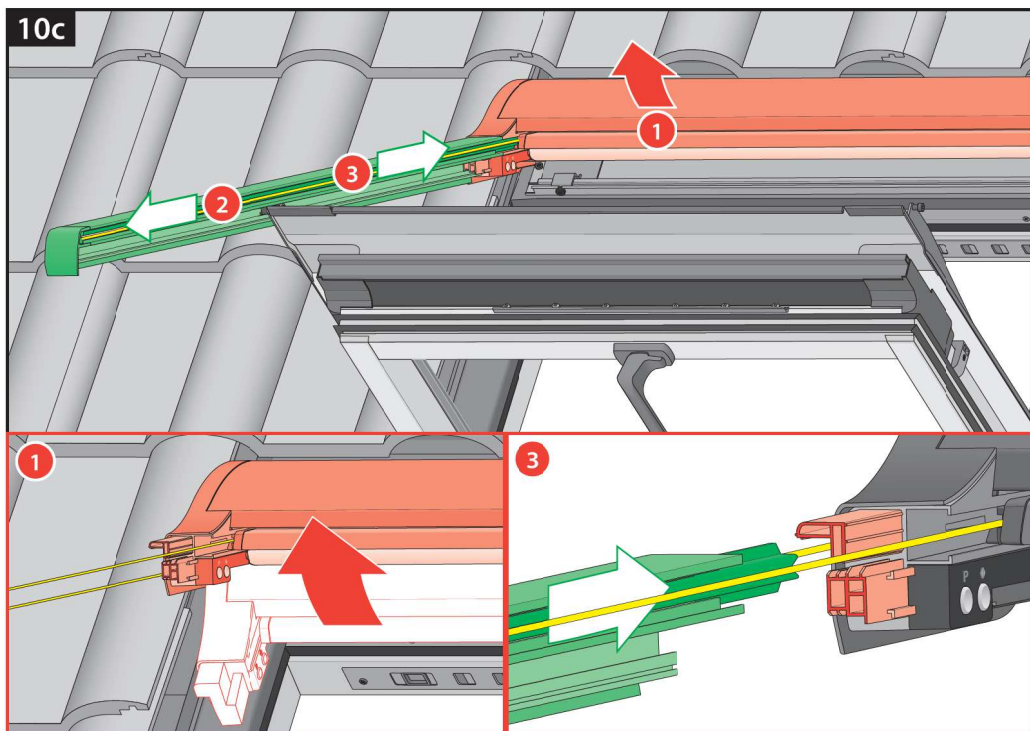
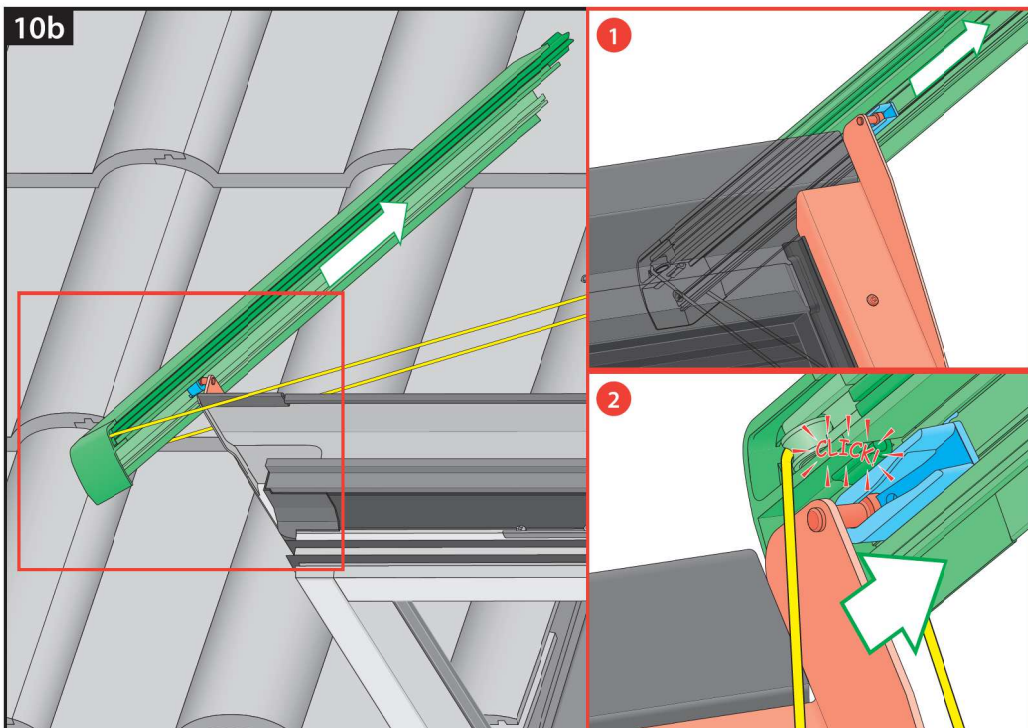

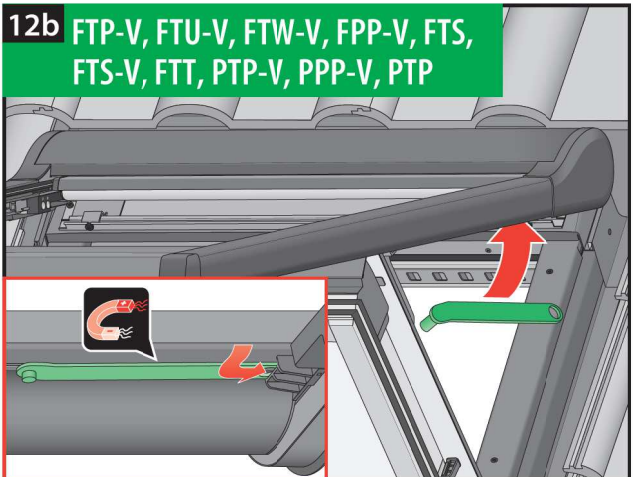
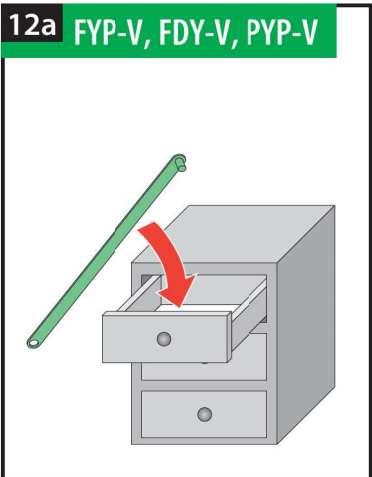
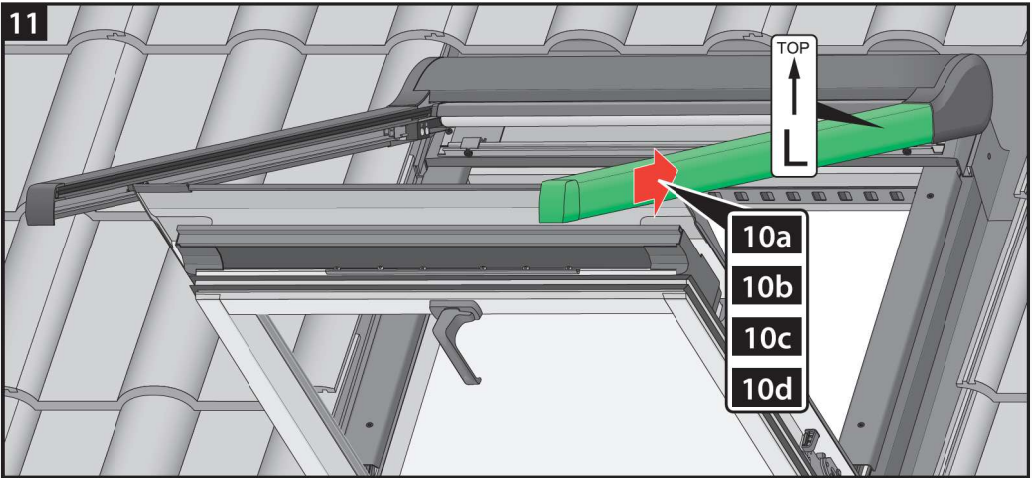
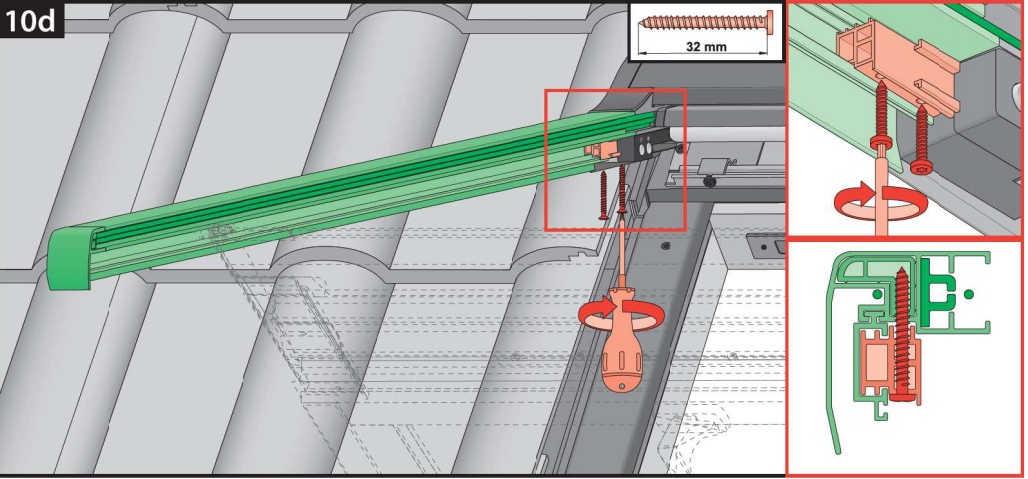

FTP-V Z-WAVE



13

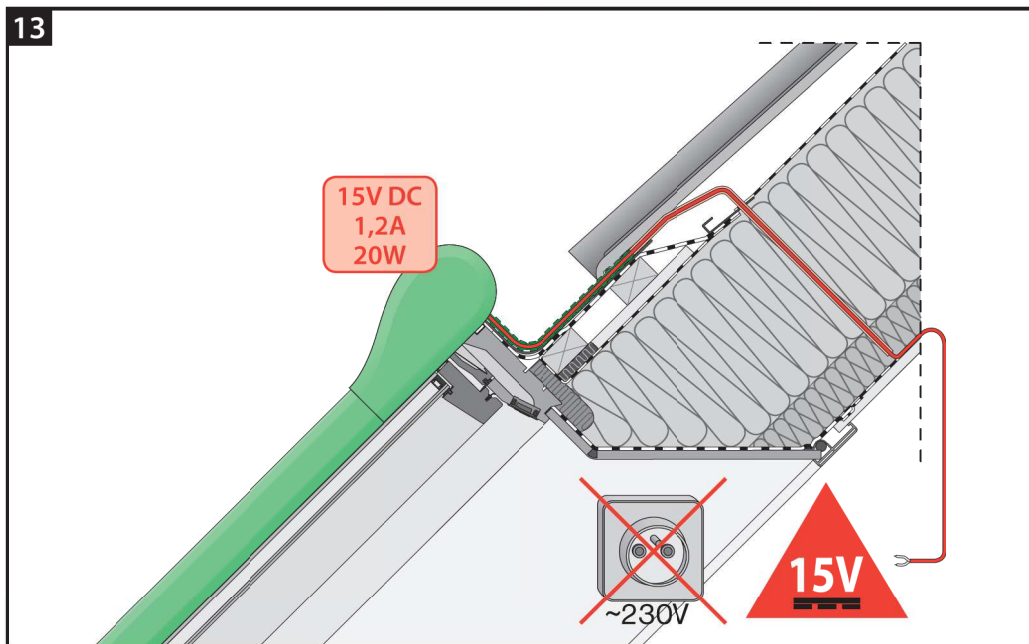

14

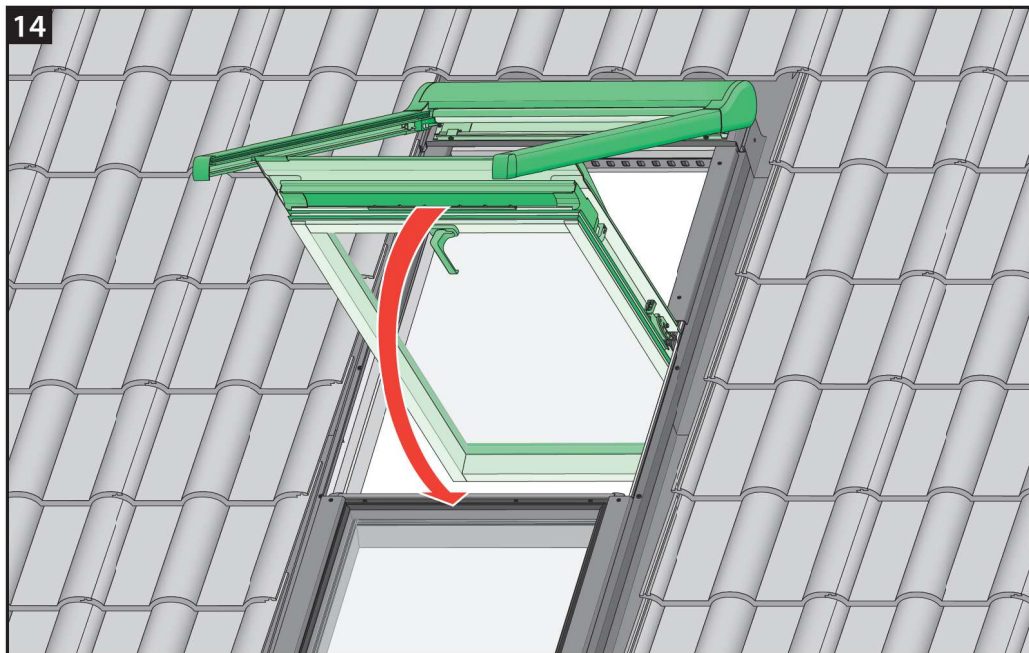

15

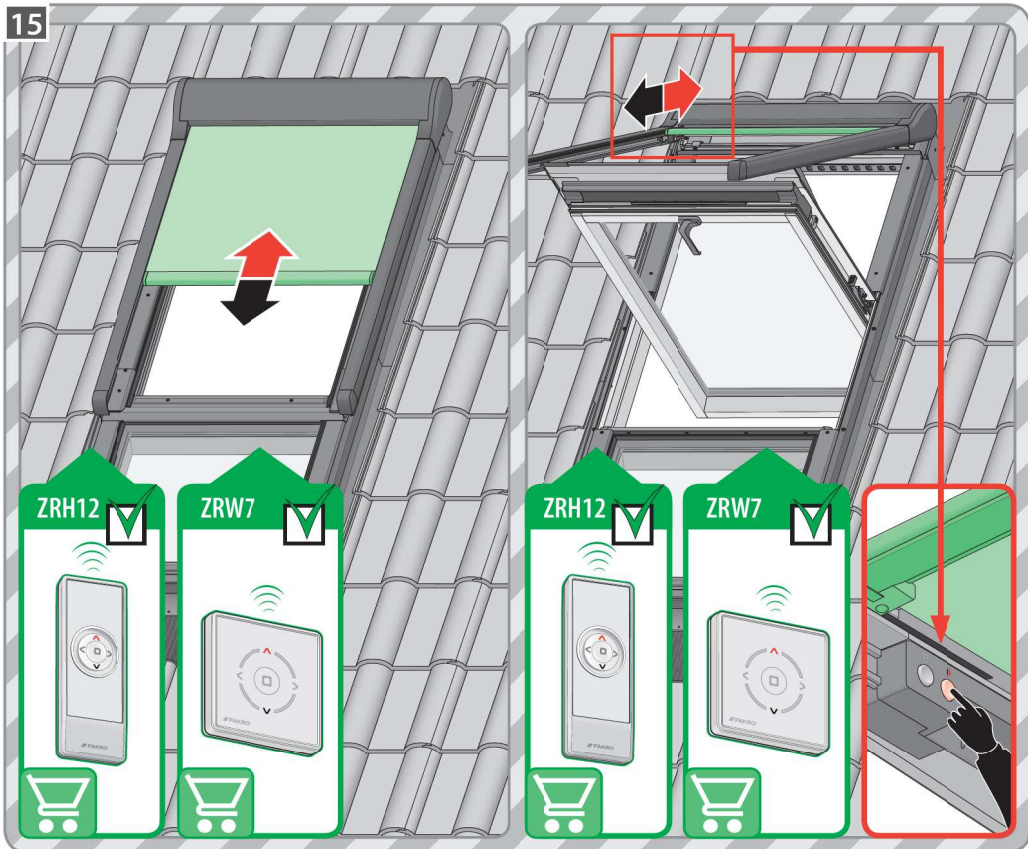

16

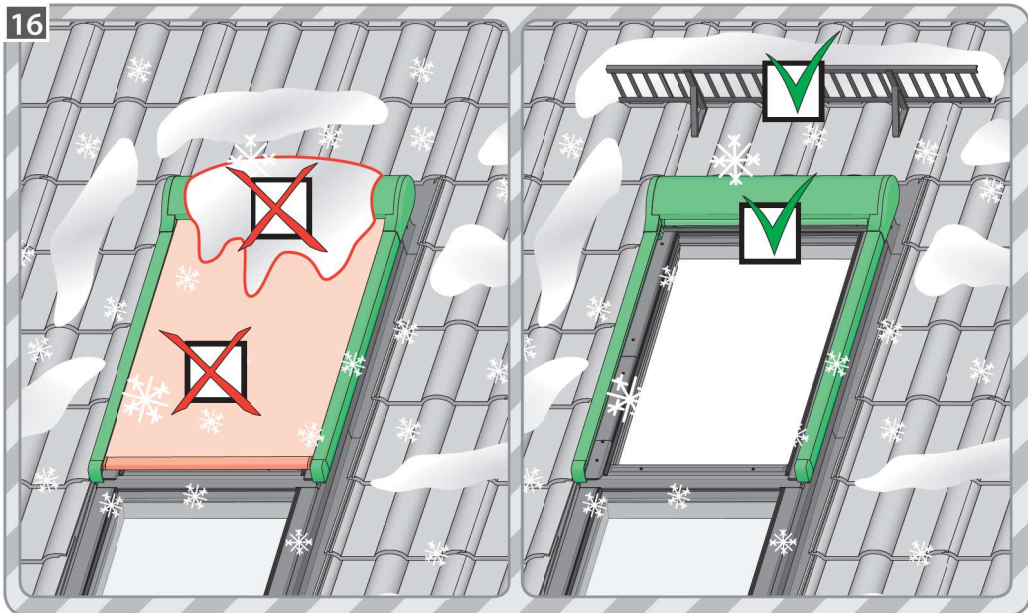

FTP-V, FTU-V, FTW-V, FPP-V, FTS,
 FTS-V, FTT, PTP-V, PPP-V, PYP-V, PTP

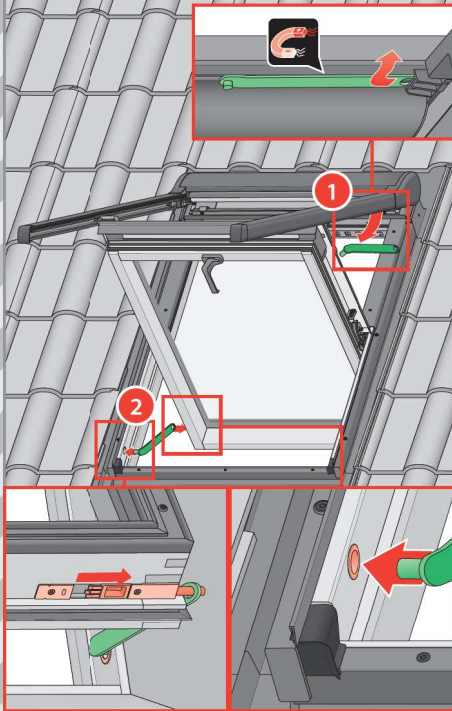

FYP-V, FDY-V, PYP-V



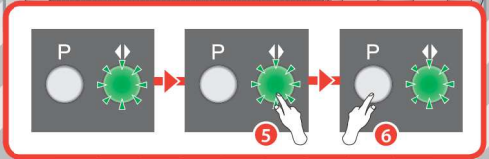
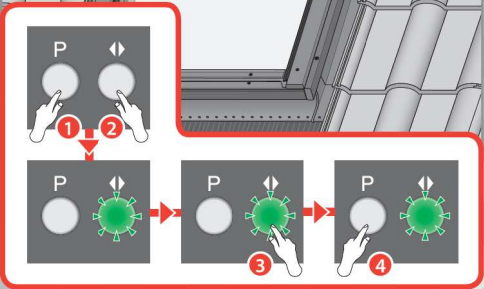
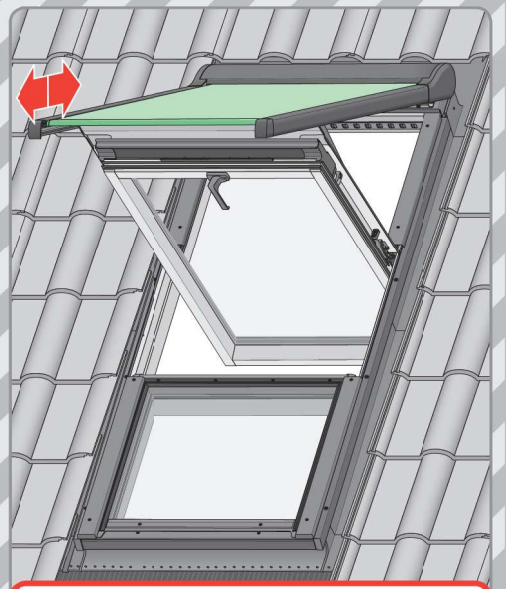
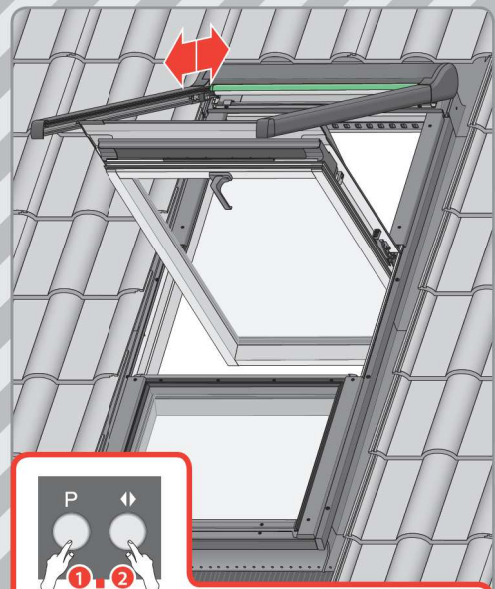
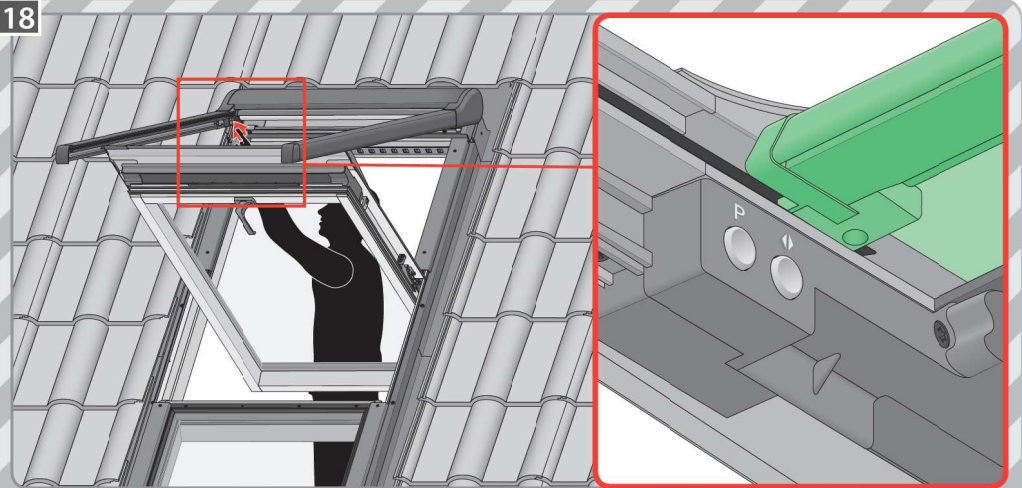

FTP-V Z-WAVE

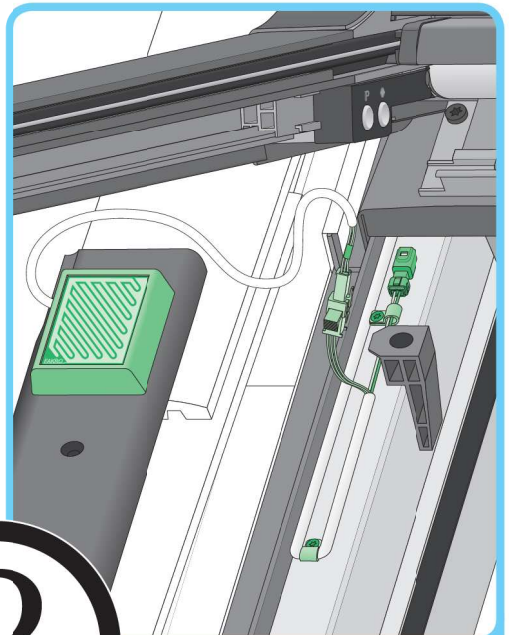
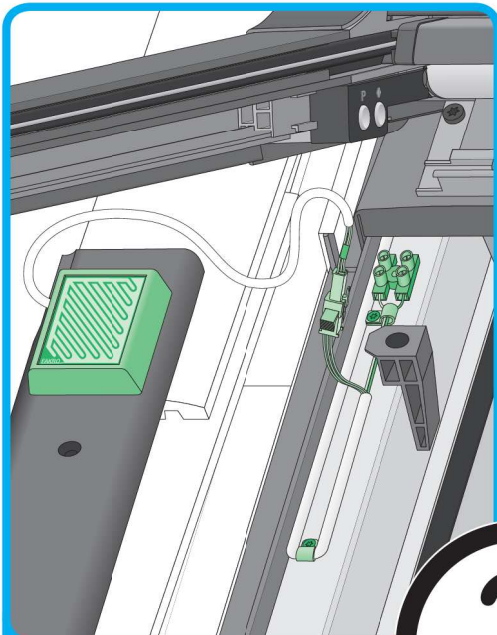
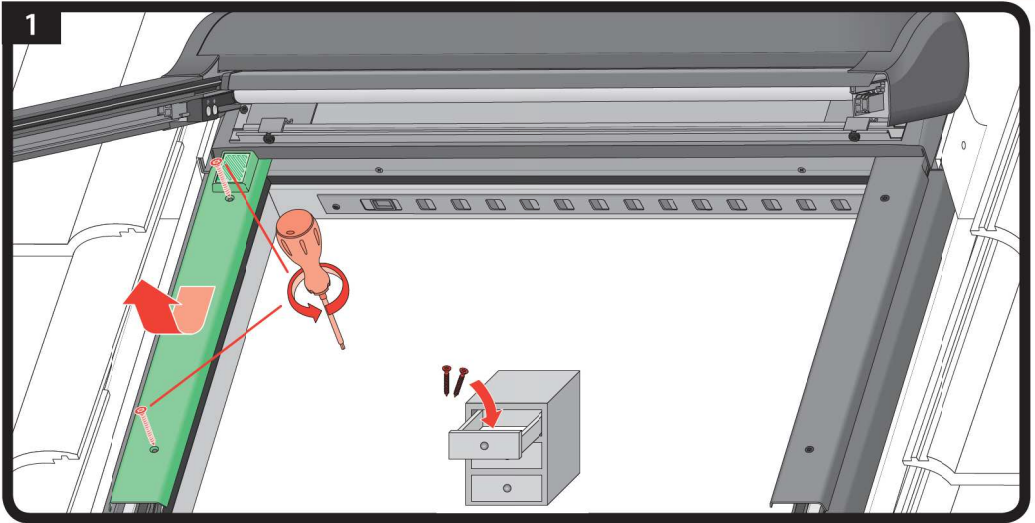

2

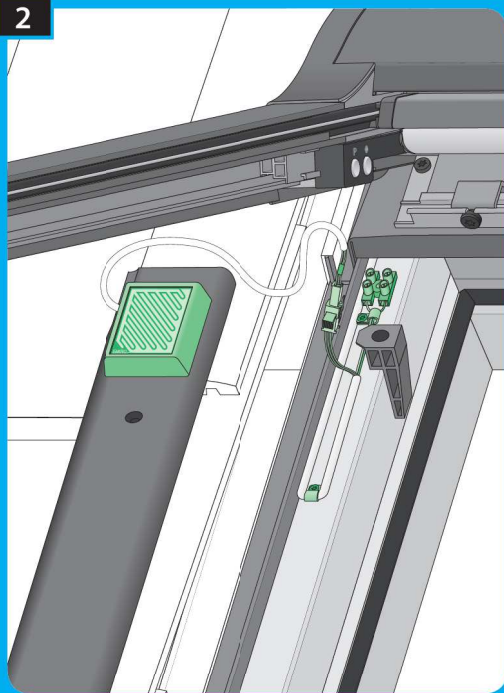

a

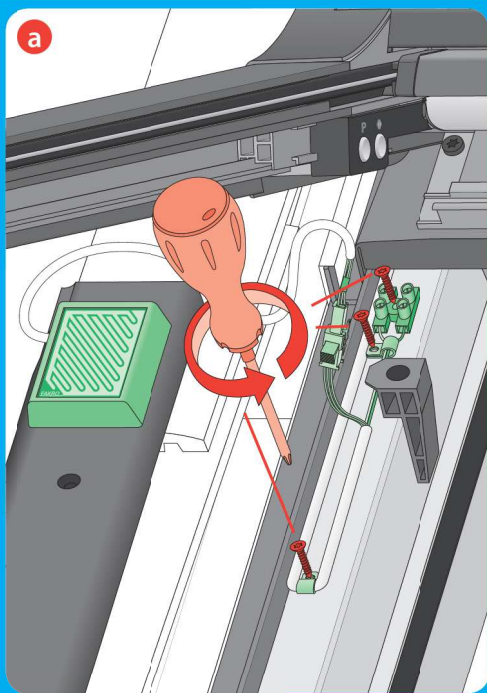

b

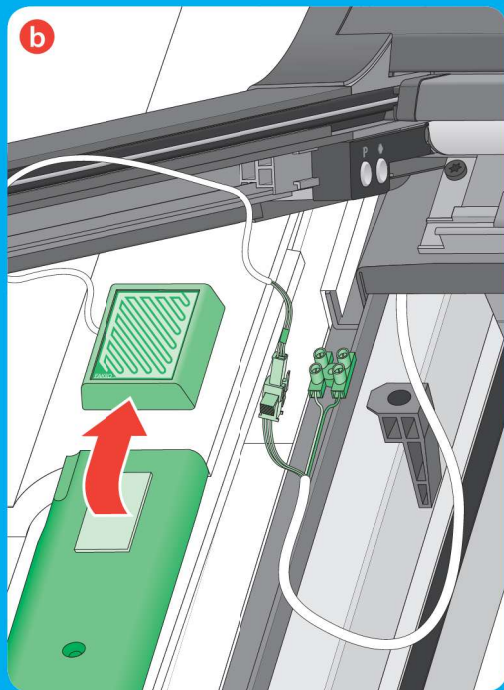

c

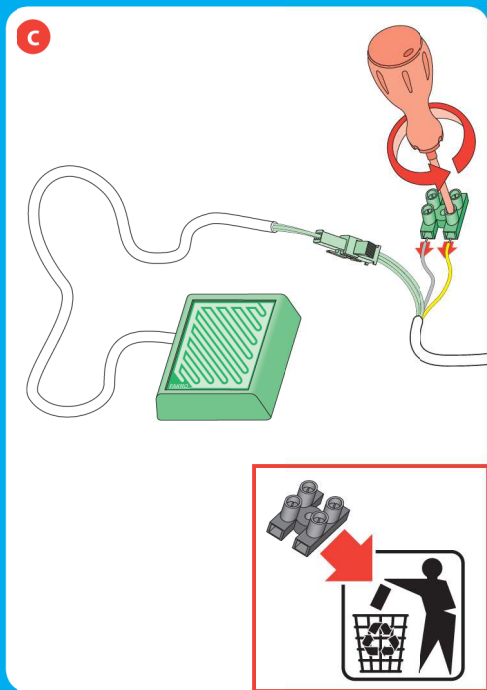

FTP-V Z-WAVE

3

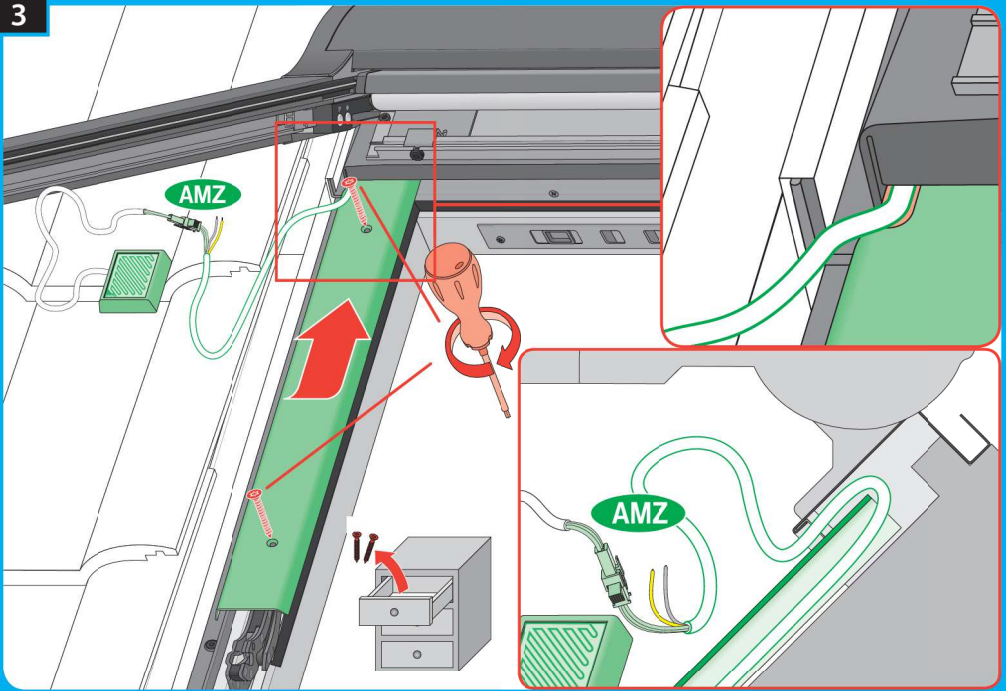

4

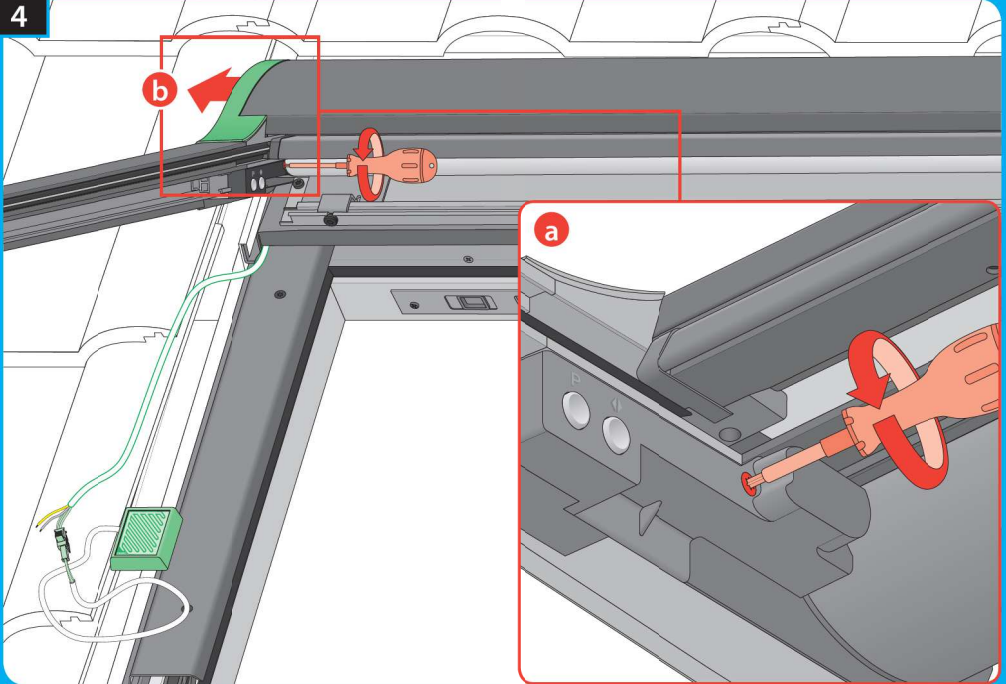

5

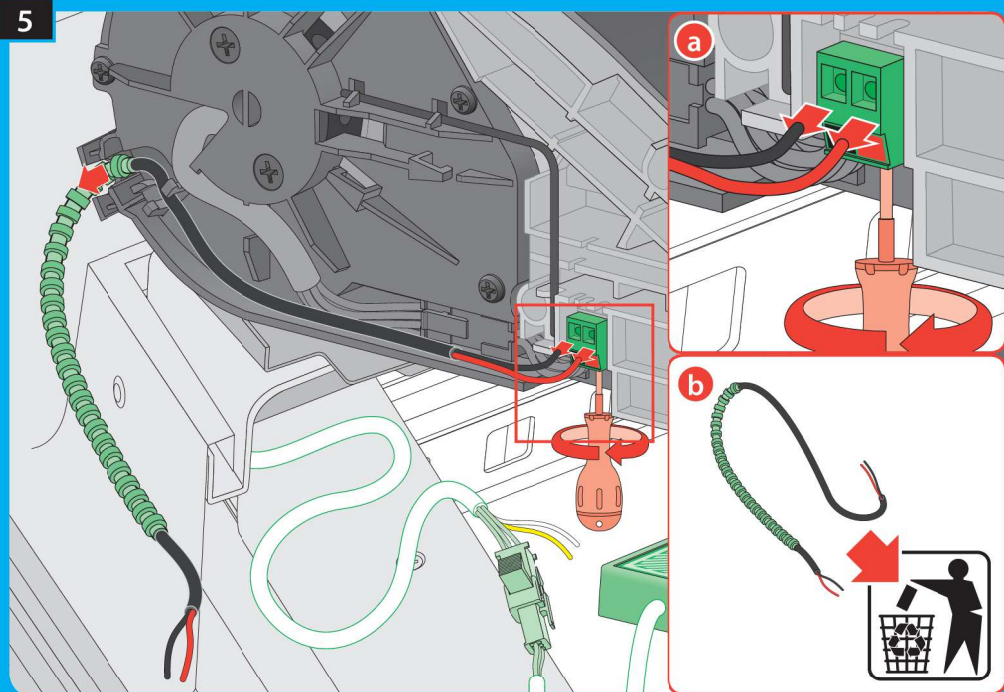

6

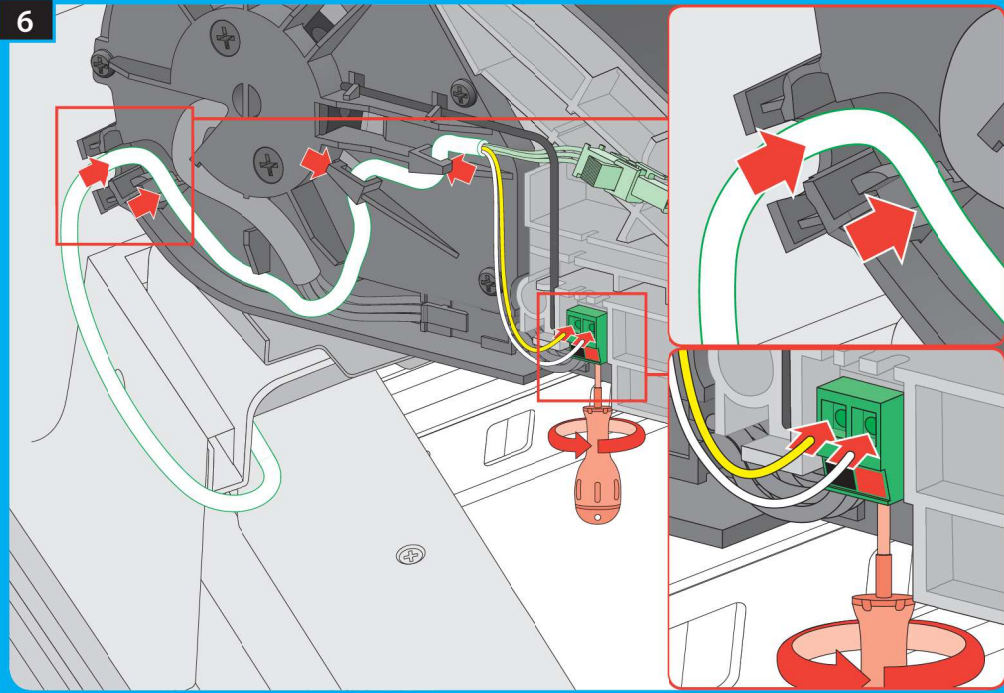

FTP-V Z-WAVE

7

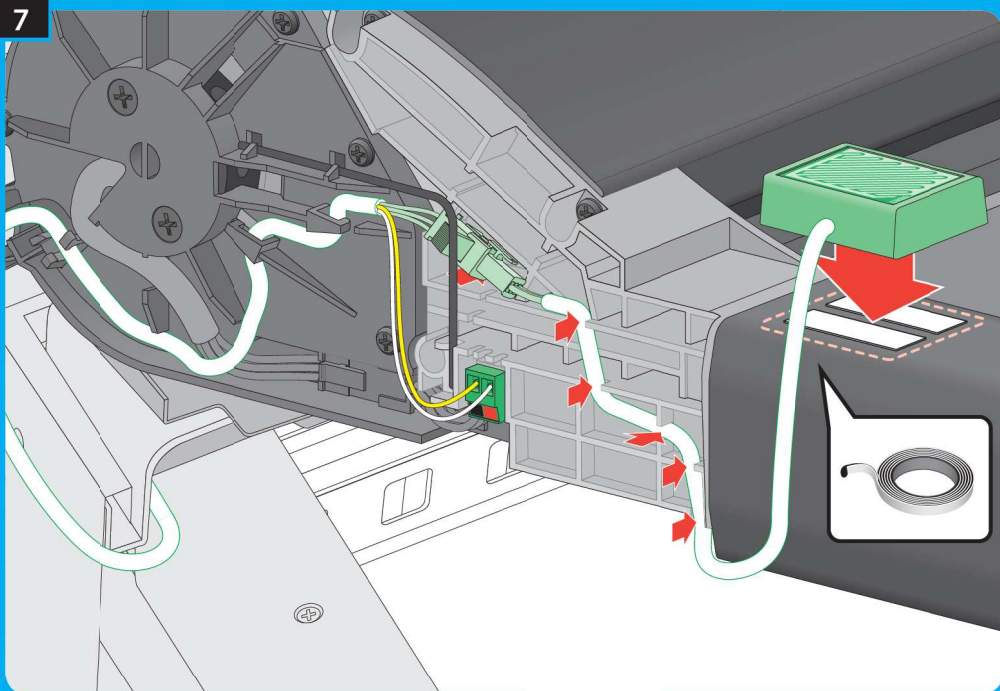

8

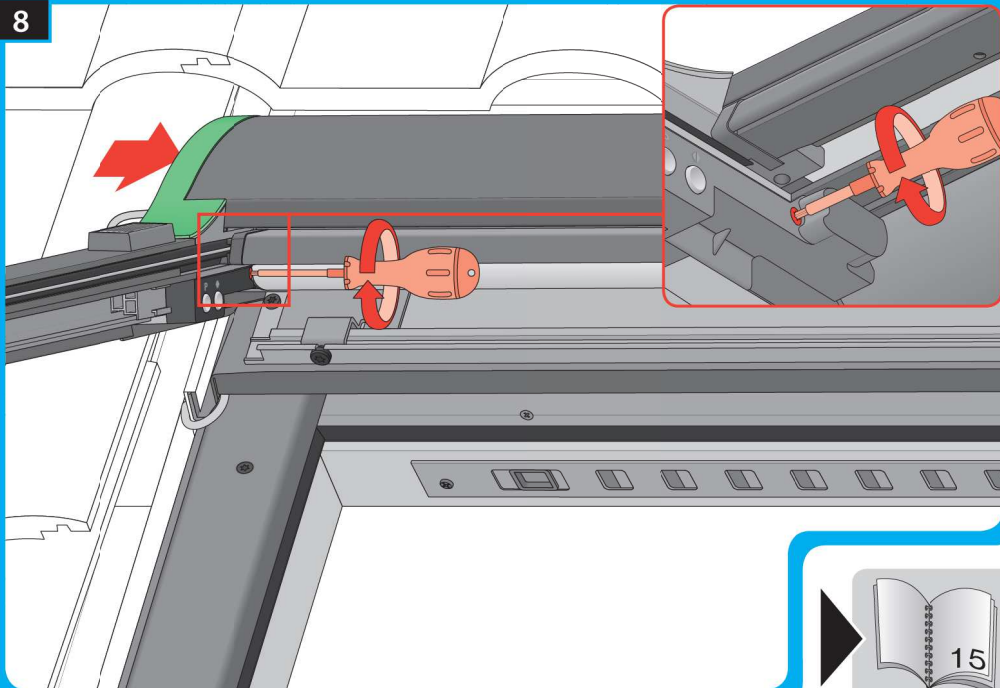

□ FTP-V Z-WAVE

2

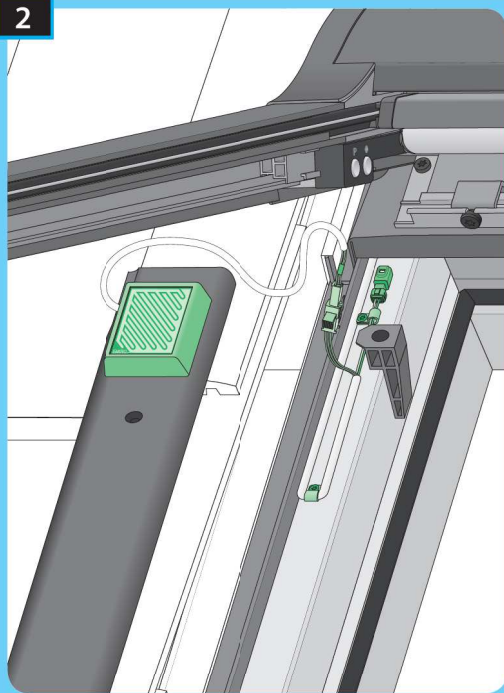

a

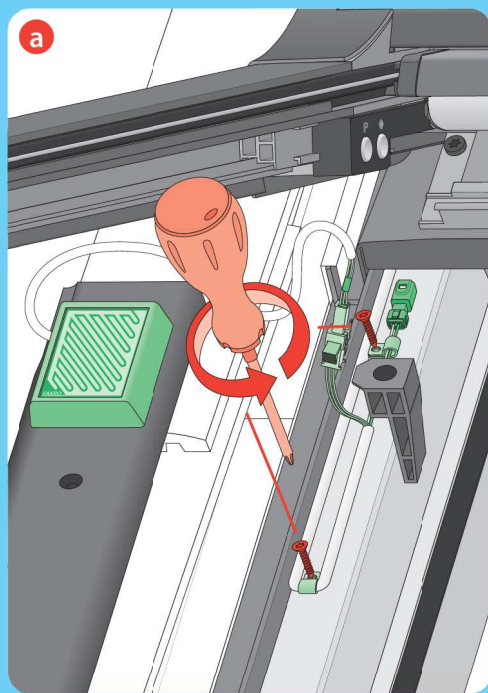

b

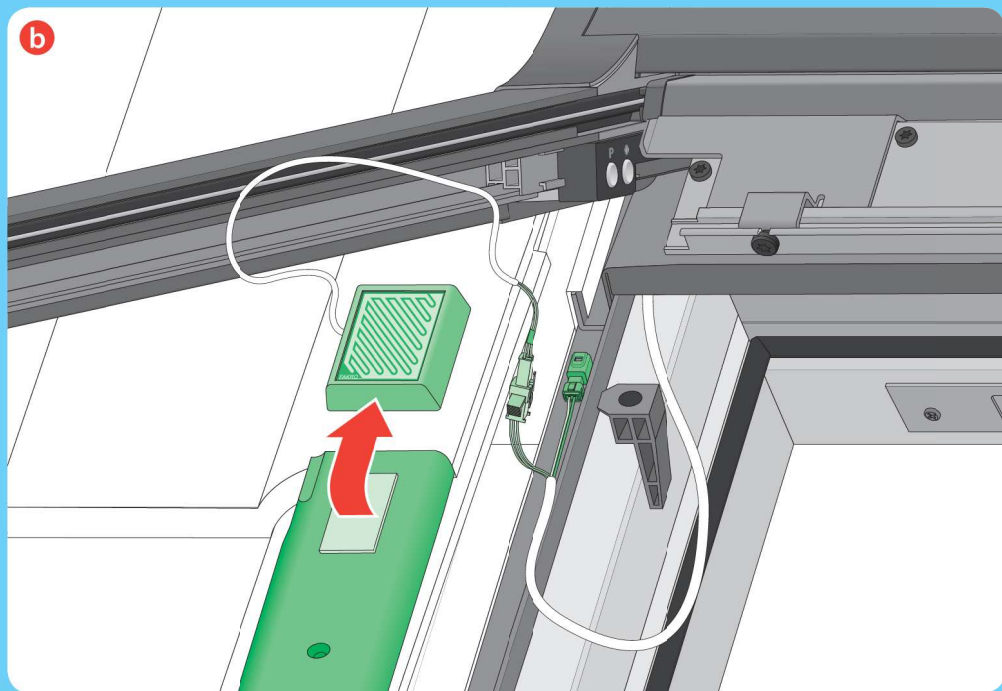

FTP-V Z-WAVE

3

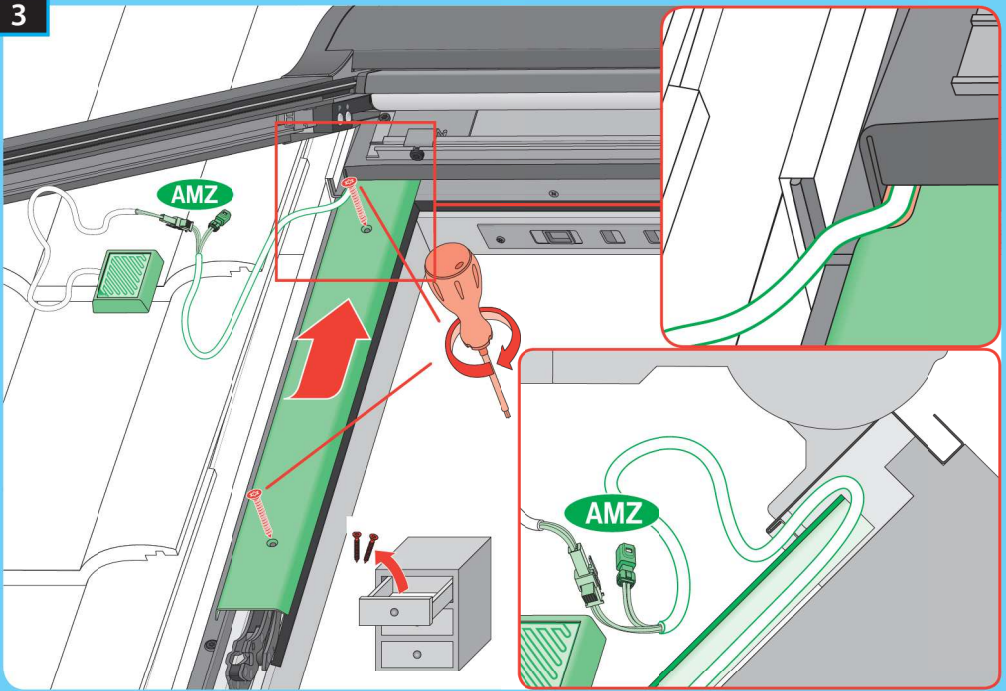

4

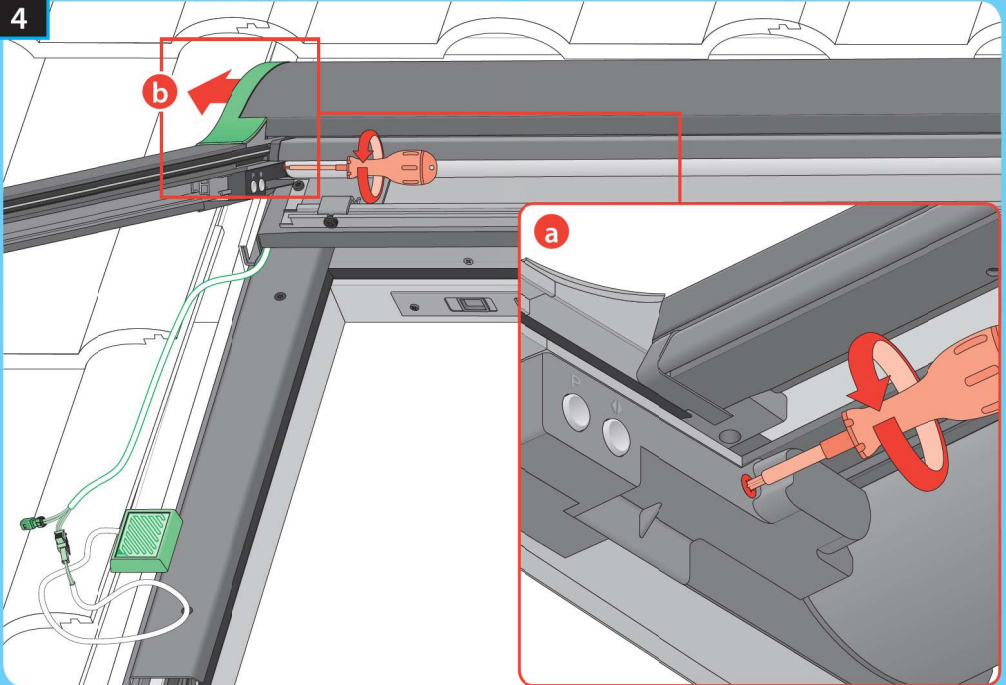

5

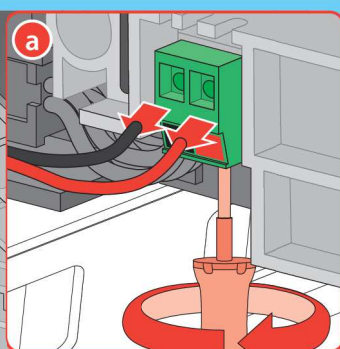
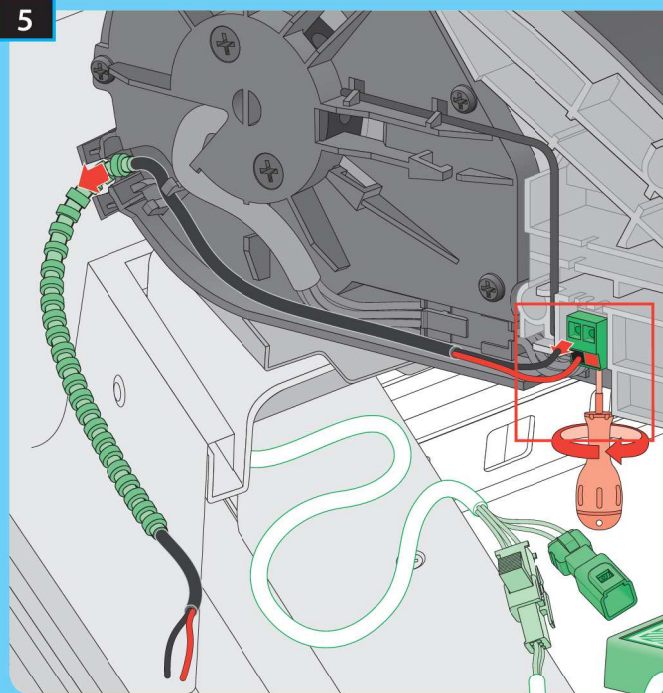

6

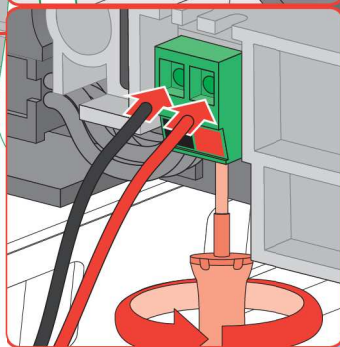
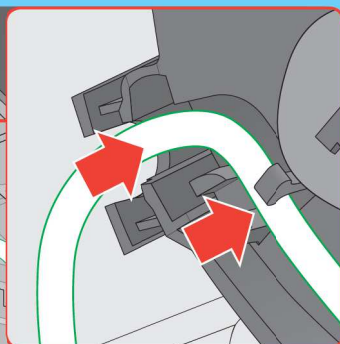
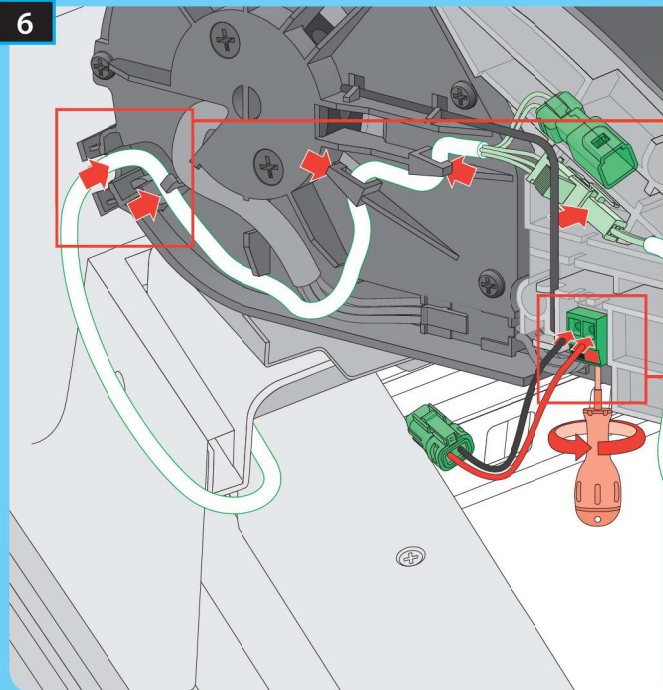

FTP-V Z-WAVE

7

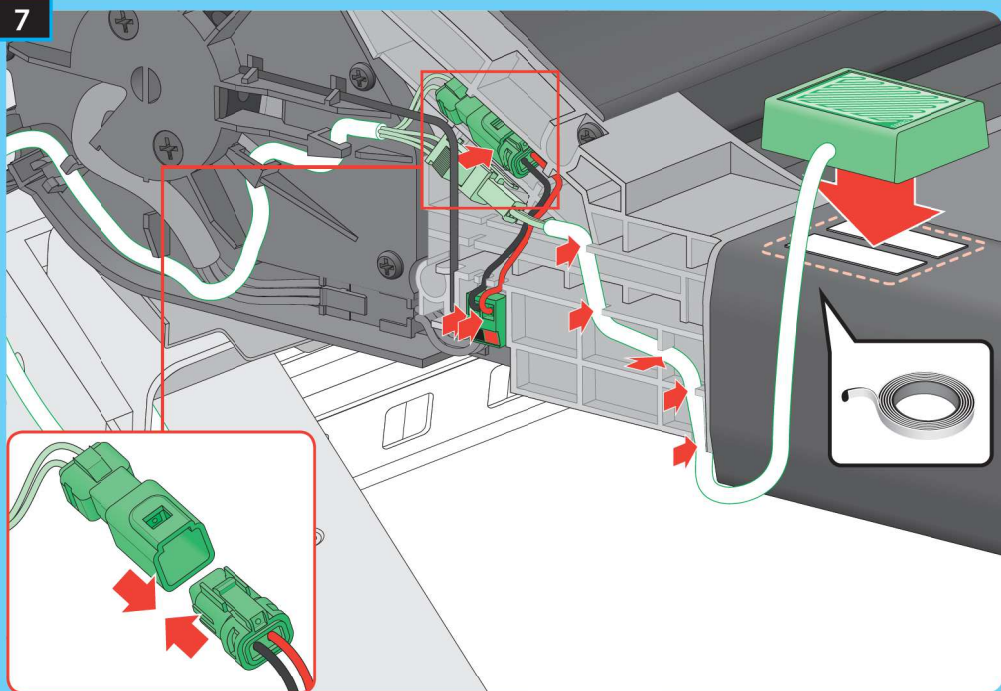

8

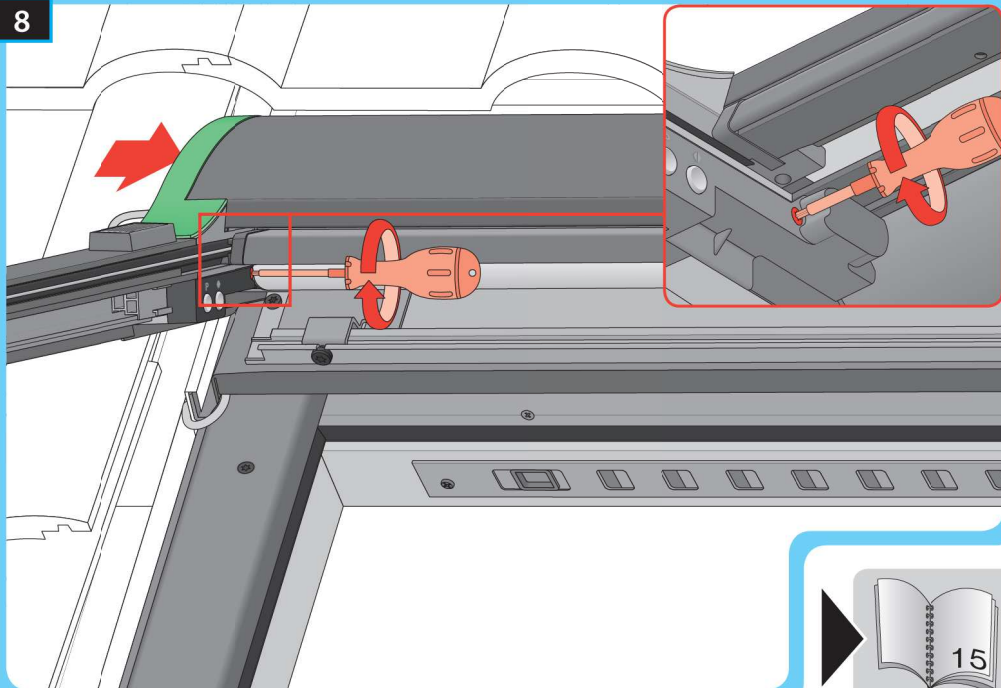

1 FYP-V, FDY-V, PYP-V

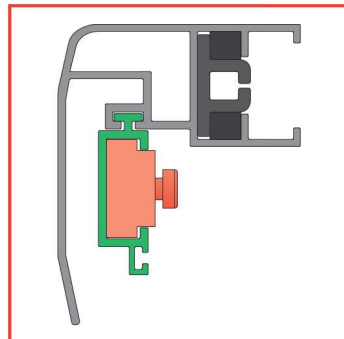
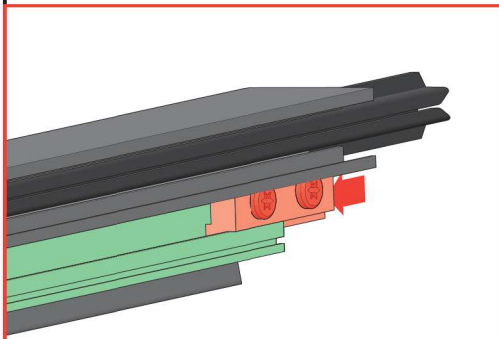
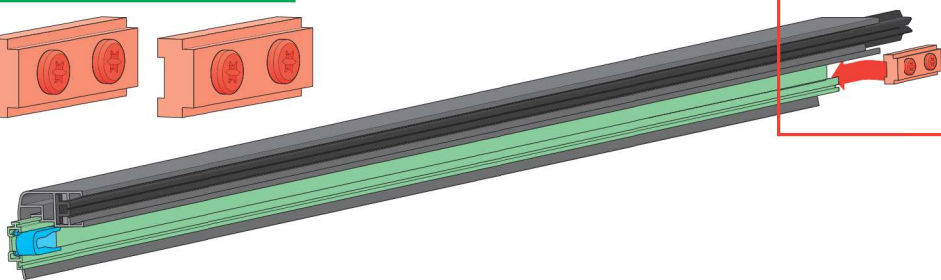
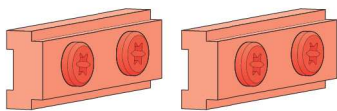

2

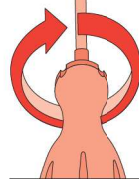
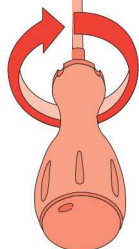
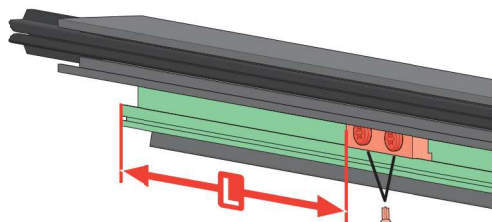
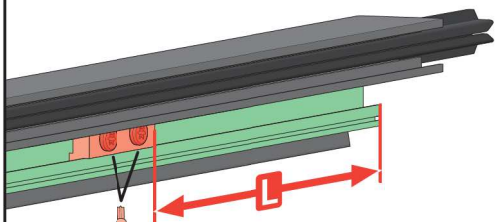

 H	L [mm]
98	295
118	350
140	550
160	550
180	600
206	660



HU	A felszerelés előtt olvassa el a következő NC9PP útmutatót „EREDETI HASZNÁLATI ÚTMUTATÓ 2/3 Felszerelési és használati előírások”.
1	Vegye ki a biztosító kapcsolót a doboz alatt.
2	Rögzítse az ablakszárnyat tolózárral.
3, 3a, 3b, 3c	A szerelőalapot az ablak felső takarólemezőnek megfelelően válasszuk ki, majd csavarjuk fel a fényvédő rolóhoz mellékelt csavarokkal.
4	Ellenőrizze, hogy az ablak rendelkezik-e furattal a kellék tápvezetéke részére.
5	Készítsen furatot a felső takarólemezen, majd tegye bele a gumi átvezetőt.
6	Csúsztassa át a tápvezetéket a furaton.
7	Helyezze a roló dobozát a szerelőalaphoz.
8	Csavarozza fel a roló rögzítőit a szerelőalaphoz.
9	Csavarozza fel a roló alsó rögzítőit az ablakszárnyra.
10a	Csúsztassa a sarokelemet a roló vezetősínébe.
10b	A vezetősín akasztóját és a roló alsó rögzítőjét össze kell kapcsolni.
10c	Csúsztassa az oldalsó vezetősínt a rolótestbe.
10d	Csavarozza fel a vezetősínt a vázra.
11	Ismételje meg a 10a-10d műveleteket a bal vezetősín számára.
12	Helyezze el a biztosító horgot a doboz alatt.
13	Csatlakoztassa a rolót a hálózatához a 15VDC tápegységén keresztül.
14	Zárja be az ablakot a szerelés befejezése után.
15	Működtesse a rolót a vezérlő vagy a távirányító gombjaival.
16	Ne hagyjon ráakódni a redőnyre nagyobb mennyiségű havat. E célból ajánlatos hófogókat alkalmazni, ami megakadályozza a hó lecsúszását a redőnyre.
17	Az ablak rögzítéséhez "tisztítás" módban használja a biztosító reteszt.
18	Szükség esetén végezze el a roló végállásainak szabályozását. - a végállások beprogramozásához, tartsa lenyomva a "P" gombot, és ezzel egyidejűleg nyomja le a nyilakkal jelzett gombot (ilyenkor a "P" világít, a nyilak villognak), - tartsa a nyilakkal jelzett gombot lenyomva addig a pillanatig, amíg a roló nem éri el a kívánt végállást, - nyugtázza a „P” gomb lenyomásával, - ugyanezzel a módszerrel állítsa be a következő végállást és nyugtázza a "P" gombbal.

PL	Przed montażem należy zapoznać się z treścią instrukcji NC9PP „INSTRUKCJA ORYGINALNA 2/3 Zasady montażu i użytkowania”.
1	Wyjąć zaczep zabezpieczający znajdujący się pod kasetą.
2	Zablokować skrzydło za pomocą zaczepu.
3, 3a, 3b, 3c	Dobrać podstawę montażową w zależności od rodzaju kaptura okna a następnie przykręcić ją za pomocą wkrętów dołączonych do zestawu montażowego markizy.
4	Sprawdzić, czy okno wyposażone jest w otwór pod przewód zasilający dodatek.
5	Wykonać otwór w kapturze a następnie umieścić w nim gumowy przepust.
6	Wsunąć przewód zasilający w otwór.
7	Umieścić kasetę markizy na podstawie montażowej.
8	Przykręcić uchwyty markizy do podstawy montażowej.
9	Przykręcić uchwyty dolne markizy do skrzydła okna.
10a	Wsunąć narożnik do prowadnicy markizy.
10b	Połączyć zaczep prowadnicy z uchwytem dolnym markizy.
10c	Wsunąć prowadnicę boczną w korpus markizy.
10d	Przykręcić prowadnicę do korpusu.
11	Powtórzyć czynności 10a-10d dla prowadnicy lewej.
12	Umieścić zaczep zabezpieczający pod kasetą.
13	Podłączyć markizę do sieci za pomocą zasilacza 15VDC.
14	Zamknąć okno po zakończonym montażu.
15	Sterować markizą za pomocą przycisku na sterowniku lub pilota.
16	Nie dopuszczać do nagromadzenia śniegu na markizie w tym celu zaleca się stosowanie urządzeń zapobiegających zsuwaniu się śniegu na markizę.
17	Do zabezpieczenia okna w pozycji „do mycia” używać zaczepu zabezpieczającego.
18	W razie potrzeby przeprowadzić regulację pozycji krańcowych markizy. - aby wejść w tryb programowania krańcówek należy trzymając wciśnięty przycisk „P” wcisnąć przycisk z symbolem strzałek (wtedy „P” świeci, strzałki migają); - przytrzymać wciśnięty przycisk strzałek aż do momentu gdy markiza osiągnie pożądane położenie krańcowe; - zatwierdzić przyciskiem „P”; - w ten sam sposób ustawić kolejną pozycję krańcową i zatwierdzić przyciskiem „P”.

DE	Lesen Sie vor der Montage die Anweisungen NC9PP „ORIGINALANLEITUNG 2/3 Montage- und Nutzungsregeln“
1	Entfernen Sie die Sicherungssperre, die sich unter der Kassette befindet.
2	Verriegeln Sie den Frontschieber mit dem Schließblech
3, 3a, 3b, 3c	Wählen Sie den Montagesockel je nach Art der Fensterhaube aus und schrauben Sie ihn anschließend mit den im Markisen-Montagesatz enthaltenen Schrauben ein.
4	Prüfen Sie, ob das Fenster mit einer Bohrung für den Netzkabelzusatz ausgestattet ist
5	Machen Sie ein Loch in die Haube und setzen Sie dann die Gummitülle hinein.
6	Führen Sie das Netzkabel in die Öffnung ein.
7	Setzen Sie die Markisenkassette auf den Montagesockel.
8	Schrauben Sie die Markisengriffe an den Montagesockel.
9	Schrauben Sie die unteren Halterungen der Markise an den Fensterflügel.
10a	Schieben Sie die Ecke in die Markisenführung.
10b	Verbinden Sie den Führungsclip mit der unteren Halterung der Markise.
10c	Setzen Sie die Seitenführung in den Markisenkörper ein.
10d	Schrauben Sie die Führungsschiene ans Gehäuse.
11	Wiederholen Sie die Schritte 10a-10d für die linke Führung.
12	Legen Sie die Sicherungssperre unter die Kassette.
13	Schließen Sie die Markise mit einem 15-VDC-Netzteil an das Stromnetz an.
14	Schliessen Sie das Fenster nach der Installation.
15	Steuern Sie die Markise mit einer Taste an der Steuerung oder der Fernbedienung.
16	Verhindern Sie, dass sich Schnee auf der Netzmarkise ansammelt. Es wird empfohlen, eine Vorrichtung zu verwenden, die verhindert, dass der Schnee auf die Netzmarkise rutscht.
17	Sichern Sie das Fenster mit der Sicherungsklinke in der Position "Reinigung".
18	Passen Sie gegebenenfalls die Endpositionen der Markise an. - um in den Grenzwertprogrammiermodus zu gelangen, drücken Sie bei gedrückter Taste „P“ die Taste mit dem Pfeilsymbol (dann leuchtet „P“, die Pfeile blinken). - halten Sie die Pfeiltaste gedrückt, bis die Netzmarkise die gewünschte Endposition erreicht hat, - drücken Sie die Taste „P“, um zu bestätigen, - stellen Sie die nächste Endposition auf die gleiche Weise ein und bestätigen Sie mit „P“.

EN	Before installation, it is compulsory to read the NC9PP „ORIGINAL INSTRUCTIONS 2/3 Installation and user manual“.
1	Remove the safety catch under the cassette.
2	Lock the sash with the catch.
3, 3a, 3b, 3c	Select the mounting base depending on the window hood type and then fix it using the screws included in the awning installation kit.
4	Check whether the window is equipped with an opening for the power cable for the accessory.
5	Make an opening in the hood and then place a rubber cable penetration.
6	Slide the power cable into the opening.
7	Place the awning cassette on the mounting base.
8	Screw the awning holders to the mounting base.
9	Screw bottom holders of the awning to the window sash.
10a	Slide the corner into the awning guide rail.
10b	Connect the guide rail catch with the awning bottom holder.
10c	Slide the side guide rail into the awning casing.
10d	Screw the guide rail to the casing.
11	Repeat steps 10a-10d for the left guide rail.
12	Place the safety catch under the cassette.
13	Connect the awning to the network using the 15VDC power supply.
14	Close the window after completed installation process.
15	Operate the awning using the button on the controller or remote control.
16	Do not allow accumulation of snow on the awning. For this purpose it is recommended to use devices preventing snow from sliding onto the awning.
17	Use the safety catch to secure the window in the position for cleaning.
18	If required, adjust the end positions of the awning. - To enter the limit switch programming mode, press the button with the arrow symbol while holding pressed the "P" button (then "P" is on, arrows are blinking). - Hold the arrow button pressed until the awning blind reaches the requested end position. - Accept using the "P" button. - Following the same procedure, set another end position and accept using the "P" button.



BG Производителите и Продавач не носят отговорност за неспазване на съответните закони, строителни норми и изисквания за безопасност от ползвателя на продукта, архитекта, монтажника или собственика на сградата.
CZ Uživatelé ani prodejci nenesou odpovědnost za nedodržení příslušných právních zákonů, stavebních předpisů a bezpečnostních požadavků výrobce, architektů, montážníků nebo vlastníků budov.
DE Hersteller und Verkäufer übernehmen keine Haftung für Nichtbeachtung entsprechender Rechts- und Bauvorschriften sowie Sicherheitsanforderungen seitens Produktbenutzers, Architekten, Monteurs oder Gebäudebesitzer.
ES El fabricante y el vendedor no tienen ninguna responsabilidad por el incumplimiento de la ley vigente, normas de construcción y exigencias de seguridad por parte del usuario del producto, arquitecto, instalador o el propietario del edificio.
FR Le fabricant et le revendeur ne prend aucune responsabilité de ne pas respecter les lois applicables, les règlements sur les bâtiments et les exigences de sécurité par l'utilisateur du produit, l'architecte, l'installateur ou le propriétaire du bâtiment.
GB Manufacturer and Seller shall bear no liability for failure to comply with the applicable laws, building codes and safety requirements by the user of the product, architect, fitter or owner of the building.
HU A gyártó és a forgalmazó nem vállal semmilyen felelősséget a vonatkozó törvények, építési és biztonsági előírások, termékfelhasználói, építész, beszerelő/tervező vagy építésszakértők által be nem tartásáért.

IT Il Produttore e il Rivenditore non potranno essere ritenuti responsabili per il mancato rispetto, da parte dell'utente del prodotto, dell'architetto, dell'installatore o del proprietario dell'edificio, delle leggi vigenti, nonché dei regolamenti edilizi e di quelli relativi alla sicurezza.
NL De fabrikant en verkoper zijn niet aansprakelijk voor gevolgen bij het niet opvolgen van toepasselijke wetten, bouwvoorschriften en veiligheidsvoorschriften door de gebruiker van het product, de architect, de installateur of de eigenaar van het gebouw.
PL Producent i Sprzedawca nie ponosi żadnej odpowiedzialności za nieprzestrzeganie stosownych przepisów prawa, przepisów budowlanych i wymogów bezpieczeństwa przez użytkowników produktu, architekta, montażystę lub właściciela budynku.
PT O fabricante e o vendedor não tem nenhuma responsabilidade pelo o não cumprimento da lei, códigos de construção e as exigências de segurança por parte do usuário do produto, arquiteto, instalador ou proprietário do edifício.
RO Nu producătorul, nici distribuitorul nu își vor asuma nici un fel de răspundere pentru neprezentarea legilor în vigoare a legilor din domeniul construcțiilor sau a măsurilor de siguranță impuse utilizatorilor produsului, arhitecților, montajorilor sau proprietarilor clădirii.
RU В случае несоблюдения архитектором, монтажником или владельцем здания строительных правил и норм безопасности ответственность производителю и продавцу не несет.
SK Výrobca a predávateľ nenesú zodpovednosť za nedodržanie príslušných ustanovení zákona, stavebných predpisov a bezpečnostných požiadaviek užívateľom výrobku, architektom, montážnikom alebo majiteľom objektu.